

(Translation. Only the Faroese version has legal validity)

Executive Order No. 119 of 22 August 2022 from the Faroese Maritime Authority on load lines and freeboard conditions

Under the provisions in section 2 subsection 2, section 7 subsection 1 and section 49 subsection 2 in Parliamentary Act No. 165 of 21 December 2001 on Safety at Sea as amended by Parliamentary Act No. 71 of 30 May 2011, Parliamentary Act No. 61 of 17 May 2013 and Parliamentary Act No. 122 of 15 December 2014 the following shall be laid down:

Scope etc.

Section 1. The executive order shall apply to vessels engaged in domestic and international voyages. These vessels shall comply with the International Convention on Load Lines, 1966, with later amendments, pursuant to Annex 1 unless otherwise expressly provided in this executive order, cf, however subsection 3.

Subsection 2. Vessels with a length of less than 24 m shall comply with sections 4-6 of this executive order instead of the Load Line Convention.

Subsection 3. Vessels of 24 metres in length and over which keel was laid before 1 January 2002 and which operate exclusively in domestic service, shall comply with the rules applicable hitherto.

Subsection 4. Vessels of less than 24 m in length which keel was laid before 1 January 2002 shall comply with the rules applicable hitherto. These vessels shall, in addition, comply with the provisions of section 6 subsection 7 or subsection 8 of this executive order.

Definitions

Section 2. For the purposes of this executive order, the following definitions apply:

- 1) Length: As defined in the Load Line Convention, Annex I, Article 3.
- 2) International voyage: a voyage from a country covered by the SOLAS Convention to a port outside that country or vice versa. Journeys between Denmark and the Faroe Islands and between Denmark and Greenland, as well as journeys between the Faroe Islands and Greenland or between two foreign ports are considered international journeys.
- 3) Domestic voyage: a voyage that is not an international journey.
- 4) Recognised organisation: an organisation authorised by the Faroese Maritime Authority carrying out surveys of vessels.

Exemption

Section 3. In addition to the possibilities for exemption mentioned in Article 6 of the Load Line Convention annex 1, the Faroese Maritime Authority may permit exemption from the provisions if the following apply to the individual vessel:

- 1) that the vessel is exclusively engaged in domestic voyage, and
- 2) that sailing in the allocated area of operation is conducted in such protected conditions that the full application of the rules would be unreasonable or unnecessary.

Marking

Section 4. The load line mark may be marked with letters indicating the issuer of the International Load Line Certificate in the following manner:

- 1) where the Load Line Certificate is issued by the Faroese Maritime Authority, F-L (Faroese Load Line) is marked.
- 2) where the Load Line Certificate is issued by a recognised organisation, endorsed in the company's chosen letters.
- 3) on vessels changing flag or recognised organisation, it may be accepted that the existing letters are retained.

Subsection 2. The bow and stern shall be marked with draught marks in decimetres on both sides. The marks are placed as close as possible to the perpendiculars.

Surveys and certificates

Section 5. The freeboard conditions appear according to Article 14 of the Load Line Convention in annex 1.

Subsection 2. The International Load Line Certificate shall be issued to vessels which have been surveyed and marked in accordance with the Load Line Convention and which comply with the provisions of this executive order.

Subsection 3. The validity and period of validity of the certificates are determined by Article 19 of the Load Line Convention in annex 1.

Freeboard conditions for vessels of less than 24 m in length

Section 6. Vessels with a length of less than 24 m must maintain a level of safety that meets the criteria of the Load Line Convention.

Subsection 2. Freeboard shall be assigned on the basis of criteria laid down in the Load Line Convention, taking into account the vessel's hull strength, stability, buoyancy and area of operation.

Subsection 3. The freeboard shall be determined from a table freeboard of 200 mm and corrected by the relevant parameters of the Load Line Convention. Where parameter values cannot be derived directly from the Load Line Convention, values used for vessels of 24 m in length and over shall be used.

Subsection 4. The freeboard of cargo vessels shall not normally be less than 150 mm. However, in special circumstances and having regard to the season and the duration of the voyage, a smaller freeboard may be permitted, but it shall never be less than 50 mm.

Subsection 5. The deck line and the freeboard mark shall be marked as specified in the Load Line Convention for a load line mark, but without the letters indicating the issuer of the Freeboard Certificate. For small vessels, the load line mark may be of a smaller diameter, but not less than 200 mm in outside diameter.

Subsection 6. The bow and stern shall bear draught marks in decimetres on both sides. The marks shall be placed as close as possible to the perpendiculars.

Subsection 7. The Faroese Maritime Authority or a recognised organisation shall indicate the approved freeboard on the National Cargo Ship Safety Certificate for cargo ships when compliance with these provisions has been ensured by a satisfactory survey. Moreover, the freeboard conditions appear in the context of the renewal of the National Cargo Ship Safety Certificate for cargo ships.

Subsection 8. In the case of passenger ships, the Faroese Maritime Authority or a recognised organisation shall indicate the approved freeboard on a Freeboard Certificate when compliance with these provisions has been ensured by a satisfactory survey. The freeboard conditions also appear in the context of the renewal of the ship's Passenger Ship Safety Certificate for passenger ships.

Penalties etc.

Section 7. Violation of sections 1 and 6 shall be punished by fine or imprisonment up to one year.

Subsection 2. Companies and other legal persons shall incur criminal liability under the regulations in chapter 5 of the Faroese Penal Code.

Section 8. This executive order comes into force the day after it has been promulgated.

Subsection 2. The construction requirements of the previous regulations shall continue to apply to existing vessels unless otherwise provided in this executive order.

The Faroese Maritime Authority, 22 August 2022

Hans Johannes á Brúgv

/Gunnvá S. á Lofti

**International Convention on Load Lines, 1966 as amended by the 1988 Protocol with later amendments
(Load Line Convention)**

Article 1	General obligation under the Convention
Article 2	Definitions
Article 3	General provisions
Article 4	Application
Article 5	Exceptions
Article 6	Exemptions
Article 7	Force majeure
Article 8	Equivalents
Article 9	Approvals for experimental purposes
Article 10	Repairs, alterations and modifications
Article 11	Zones and areas
Article 12	Submersion
Article 13	Surveys and marking
Article 14	Initial, renewal and annual surveys
Article 15	Maintenance of conditions after survey
Article 16	Issue of certificates
Article 17	Issue or endorsement of certificates by another Government
Article 18	Form of certificates
Article 19	Duration and validity of certificates
Article 20	Acceptance of certificates
Article 21	Control
Article 22	Privileges
Article 23	Casualties
Article 24	Prior treaties and conventions
Article 25	Special rules drawn up by agreement
Article 26	Communication of information
Article 27	Signature, acceptance and accession
Article 28	Coming into force
Article 29	Amendments
Article 30	Denunciation
Article 31	Suspension
Article 32	Territories
Article 33	Registration
Article 34	Languages
Annex I	Regulations for determining load lines
Chapter I	General
Regulation 1	Strength and intact stability of ships
Regulation 2	Application
Regulation 2-1	Authorization of recognized organizations
Regulation 3	Definitions of terms used in the Annexes
Regulation 4	Deck line
Regulation 5	Load line mark
Regulation 6	Lines to be used with the load line mark
Regulation 7	Mark of assigning authority
Regulation 8	Details of marking

Regulation 9	Verification of marks
Chapter II	Conditions of assignment of freeboard
Regulation 10	Information to be supplied to the master
Regulation 11	Superstructure end bulkheads
Regulation 12	Doors
Regulation 13	Position of hatchways, doorways and ventilators
Regulation 14	Cargo and other hatchways
Regulation 14-1	Hatchway coamings
Regulation 15	Hatchways closed by portable covers and secured weathertight by tarpaulins and battening devices
Regulation 16	Hatchways closed by weathertight covers of steel or other equivalent materials
Regulation 17	Machinery space openings
Regulation 18	Miscellaneous openings in freeboard and superstructure decks
Regulation 19	Ventilators
Regulation 20	Air pipes
Regulation 21	Cargo ports and other similar openings
Regulation 22	Scuppers, inlets and discharges
Regulation 22-1	Garbage chutes
Regulation 22-2	Spurling pipes and cable lockers
Regulation 23	Side scuttles, windows and skylights
Regulation 24	Freeing ports
Regulation 25	Protection of the crew
Regulation 25-1	Means for safe passage of crew
Regulation 26	Special conditions of assignment for type "A" ships
Chapter III	Freeboards
Regulation 27	Types of ships
Regulation 28	Freeboard tables
Regulation 29	Correction to the freeboard for ships under 100 m in length
Regulation 30	Correction for block coefficient
Regulation 31	Correction for depth
Regulation 32	Correction for position of deck line
Regulation 32-1	Correction for recess in freeboard deck
Regulation 33	Standard height of superstructure
Regulation 34	Length of superstructure
Regulation 35	Effective length of superstructure
Regulation 36	Trunks
Regulation 37	Deduction for superstructures and trunks
Regulation 38	Sheer
Regulation 39	Minimum bow height and reserve buoyancy
Regulation 40	Minimum freeboards
Chapter IV	Special requirements for ships assigned timber freeboards
Regulation 41	Application of this chapter
Regulation 42	Definitions
Regulation 43	Construction of the ship
Regulation 44	Stowage
Regulation 45	Computation for freeboard
	Annex II
	Zones, areas and seasonal periods
Regulation 46	Northern winter seasonal zones and area

Regulation 47	Southern winter seasonal zone
Regulation 48	Tropical zone
Regulation 49	Seasonal tropical areas
Regulation 50	Summer zones
Regulation 51	Enclosed seas
Regulation 52	The winter North Atlantic load line
	Load line zone chart
	Annex III
	Certificates
	Annex IV
	Verification of compliance with the provisions of this Convention
Regulation 53	Application
Regulation 54	Verification of compliance

INTERNATIONAL CONVENTION ON LOAD LINES, 1966

THE CONTRACTING GOVERNMENTS,

DESIRING to establish uniform principles and rules with respect to the limits to which ships on international voyages may be loaded having regard to the need for safeguarding life and property at sea;

CONSIDERING that this end may best be achieved by conclusion of a Convention;

HAVE AGREED as follows:

Article 1

General obligation under the Convention

- (1) The Contracting Governments undertake to give effect to the provisions of the present Convention and the Annexes hereto, which shall constitute an integral part of the present Convention. Every reference to the present Convention constitutes at the same time a reference to the Annexes.
- (2) The Contracting Governments shall undertake all measures which may be necessary to give effect to the present Convention.

Article 2

Definitions

For the purpose of the present Convention, unless expressly provided otherwise:

- (1) "Regulations" means the Regulations annexed to the present Convention.
- (2) "Administration" means the Government of the State whose flag the ship is flying.
- (3) "Approved" means approved by the Administration.
- (4) "International voyage" means a sea voyage from a country to which the present Convention applies to a port outside such country, or conversely. For this purpose, every territory for the international relations of which a Contracting Government is responsible or for which the United Nations are the administering authority is regarded as a separate country.
- (5) A "fishing vessel" is a ship used for catching fish, whales, seals, walrus or other living resources of the sea.
- (6) "New ship" means a ship the keel of which is laid, or which is at a similar stage of construction, on or after the date of coming into force of the present Convention for each Contracting Government.
- (7) "Existing ship" means a ship which is not a new ship.
- (8) "Length" means 96% of the total length on a waterline at 85% of the least moulded depth measured from the top of the keel, or the length from the fore-side of the stem to the axis of the rudder stock on that waterlines if that be greater. Where the stem contour is concave above the waterline at 85% of the least moulded depth, both the forward terminal of the total length and the fore-side of the stem respectively shall be taken at the vertical projection to that waterline of the after most point of the stem contour (above that waterline). In ships designed with a rake of keel the waterline on which this length is measured shall be parallel to the designed waterline."
- (9) "Anniversary date" means the day and the month of each year which will correspond to the date of expire of the relevant certificate.

Article 3

General provisions

- (1) No ship to which the present Convention applies shall proceed to sea on an international voyage after the date on which the present Convention comes into force unless it has been surveyed, marked and provided with an International Load Line Certificate or, where appropriate, an International Load Line Exemption Certificate in accordance with the provisions of the present Convention.
- (2) Nothing in this Convention shall prevent an Administration from assigning a greater freeboard than the minimum freeboard in accordance with Annex I.

Article 4

Application

- (1) The present Convention shall apply to :
 - (1)(a) ships registered in countries the Governments of which are Contracting Governments;
 - (1)(b) ships registered in territories to which the present Convention is extended under Article 32; and
 - (1)(c) unregistered ships flying the flag of a State, the Government of which is a Contracting Government.
- (2) The present Convention shall apply to ships engaged on international voyages.
- (3) The regulations contained in annex I, unless expressly provided otherwise, are applicable to new ships.
- (4) Existing ships which do not fully comply with the requirements of the Regulations contained in Annex I or any part thereof shall meet at least such lesser related requirements as the Administration applied to ships on international voyages prior to the coming into force of the present Convention; in no case shall such ships be required to increase their freeboards. In order to take advantage of any reduction in freeboard from that previously assigned, existing ships shall comply with all the requirements of the present Convention.
- (5) The Regulations contained in Annex II are applicable to new and existing ships to which the present Convention applies.

Article 5

Exceptions

- (1) The present Convention shall not apply to:
 - (1)(a) ships of war;
 - (1)(b) new ships of less than 24 metres (79 feet) in length;
 - (1)(c) existing ships of less than 150 gross tonnage;
 - (1)(d) pleasure yachts not engaged in trade;
 - (1)(e) fishing vessels.
- (2) Nothing herein shall apply to ships solely navigating:
 - (2)(a) the Great Lakes of North America and the River St. Lawrence as far east, as a rhumb line drawn from Cap des Rosiers to West Point, Anticosti Island, and, on the north side of Anticosti Island, the meridian of longitude 63°W;
 - (2)(b) the Caspian Sea;
 - (2)(c) the Plate, Parana and Uruguay Rivers as far east as a rhumb line drawn between Punta Rasa (Cabo San Antonio), Argentina, and Punta del Este, Uruguay.

Article 6

Exemptions

- (1) Ships when engaged on international voyages between the near neighbouring ports of two or more States may be exempted by the Administration from the provisions of the present Convention, so long as they shall remain engaged on such voyages, if the Governments of the States in which such ports are situated shall be satisfied that the sheltered nature or conditions of such voyages between such ports make it unreasonable or impracticable to apply the provisions of the present Convention to ships engaged on such voyages.
- (2) The Administration may exempt any ship which embodies features of a novel kind from any of the provisions of this Convention the application of which might seriously impede research into the development of such features and their incorporation in ships engaged on international voyages. Any such ship shall, however, comply with safety requirements, which, in the opinion of that Administration, are adequate for the service for which it is intended and are such as to ensure the overall safety of the ship and which are acceptable to the Governments of the States to be visited by the ship.
- (3) The Administration which allows any exemption under paragraphs (1) and (2) of this Article shall communicate to the Inter-Governmental Maritime Consultative Organization (hereinafter called the Organization) particulars of the same and reasons therefore which the Organization shall circulate to the Contracting Governments for their information.

(4) A ship which is not normally engaged on international voyages but which, in exceptional circumstances, is required to undertake a single international voyage may be exempted by the Administration from any of the requirements of the present Convention, provided that it complies with safety requirements which, in the opinion of that Administration, are adequate for the voyage which is to be undertaken by the ship.

Article 7

Force majeure

(1) A ship which is not subject to the provisions of the present Convention at the time of its departure on any voyage shall not become subject to such provisions on account of any deviation from its intended voyage due to stress of weather or any other cause of force majeure.

(2) In applying the provisions of the present Convention, the Contracting Governments shall give due consideration to any deviation or delay caused to any ship owing to stress of weather or any other cause of force majeure.

Article 8

Equivalents

(1) The Administration may allow any fitting, material, appliance or apparatus to be fitted, or any other provision to be made in a ship, other than that required by the present Convention, if it is satisfied by trial thereof or otherwise that such fitting, material, appliance or apparatus, or provision, is at least as effective as that required by the Convention.

(2) The Administration which allows a fitting, material, appliance or apparatus, or provision, other than that required by the present Convention, shall communicate to the Organization for circulation to the Contracting Governments particulars thereof, together with a report on any trials made.

Article 9

Approvals for experimental purposes

(1) Nothing in the present Convention shall prevent an Administration from making specific approvals for experimental purposes in respect of a ship to which the Convention applies.

(2) An Administration which makes any such approval shall communicate to the Organization for circulation to the Contracting Governments particulars thereof.

Article 10

Repairs, alterations and modifications

(1) A ship which undergoes repairs, alterations, modifications and outfitting related thereto shall continue to comply with at least the requirements previously applicable to the ship. An existing ship in such a case shall not, as a rule, comply to a lesser extent with the requirements for a new ship than it did before.

(2) Repairs, alterations and modifications of a major character and outfitting related thereto should meet the requirements for a new ship in so far as the Administration deems reasonable and practicable.

Article 11

Zones and areas

(1) A ship to which the present Convention applies shall comply with the requirements applicable to that ship in the zones and areas described in Annex II.

(2) A port standing on the boundary line between two zones or areas shall be regarded as within the zone or area from or into which the ship arrives or departs.

Article 12

Submersion

(1) Except as provided in paragraphs (2) and (3) of this Article, the appropriate loadlines on the sides of the ship corresponding to the season of the year and the zone or area in which the ship may be shall not be submerged at any time when the ship puts to sea, during the voyage or on arrival.

(2) When a ship is in fresh water of unit density the appropriate load line may be submerged by the amount of the fresh water allowance shown on the International Load Line Certificate. Where the density is other than unity, an allowance shall be made proportional to the difference between 1.025 and the actual density.

(3) When a ship departs from a port situated on a river or inland waters, deeper loading shall be permitted corresponding to the weight of fuel and all other materials required for consumption between the point of departure and the sea.

Article 13

Surveys and marking

The surveys and marking of ships, as regards the enforcement of the provisions of the present Convention and the granting of exemptions therefrom, shall be carried out by officers of the Administration. The Administration may, however, entrust the surveys and marking either to surveyors nominated for the purpose or to organizations recognized by it. In every case the Administration concerned fully guarantees the completeness and efficiency of the surveys and marking.

Article 14

Initial, renewal and annual surveys

(1) A ship shall be subjected to the surveys specified below:

(1)(a) An initial survey before the ship is put in service, which shall include a complete inspection of its structure and equipment in so far as the ship is covered by the present Convention. The survey shall be such as to ensure that the arrangements, materials and scantlings fully comply with the requirements of the present Convention.

(1)(b) A renewal survey at intervals specified by the Administration but not exceed 5 years, except where paragraphs (2), (5), (6) and (7) of article 19 are applicable, which shall be such as to ensure that the structure, equipment, arrangements, materials and scantlings fully comply with the requirements of the present Convention.

(1)(c) An annual survey within 3 months before or after each anniversary date of the certificate to ensure that:

(1)(c)(i) alterations have not been made to the hull or superstructures which would affect the calculations determining the position of the load line;

(1)(c)(ii) the fittings and appliances for the protection of openings guard rails, freeing ports and means of access to crew quarters are maintained in an effective condition;

(1)(c)(iii) the freeboard marks are correctly and permanently indicated;

(1)(c)(iv) the information required by regulation 10 is provided.

(2) The annual surveys referred to in paragraph (1)(c) of this article shall be endorsed on the International Load Line Certificate or the International Load Line Exemption Certificate issued to a ship exempted under paragraph (2) of article 6 of the present Convention.

Article 15

Maintenance of conditions after survey

After any survey of the ship under Article 14 has been completed, no change shall be made in the structure, equipment, arrangements, material or scantlings covered by the survey, without the sanction of the Administration.

Article 16

Issue of certificates

(1) An International Load Line Certificate shall be issued to every ship which has been surveyed and marked in accordance with the present Convention.

(2) An International Load Line Exemption Certificate shall be issued to any ship to which an exemption has been granted under and in accordance with paragraph (2) or (4) of Article 6.

(3) Such certificates shall be issued by the Administration or by any person or organization duly authorized by it. In every case, the Administration assumes full responsibility for the certificate.

Article 17

Issue or endorsement of certificates by another Government

(1) A Contracting Government may at the request of another Contracting Government cause a ship to be surveyed and, if satisfied that the provisions of the present Convention are complied with, shall issue or authorize the issue of the International Load Line Certificate to the ship and, where appropriate, endorse or authorize the endorsement of the certificate on the ship in accordance with the present Convention.

(2) A copy of the certificate, a copy of the survey report used for computing the freeboard, and a copy of the

computations shall be transmitted as early as possible to the requesting Government.

(3) A certificate so issued must contain a statement to the effect that it has been issued at the request of the Government of the State whose flag the ship is or will be flying and it shall have the same force and receive the same recognition as a certificate issued under Article 16.

(4) No International Load Line Certificate shall be issued to a ship which is flying the flag of a State the Government of which is not a Contracting Government.

Article 18

Form of certificates

The certificates shall be drawn up in the form corresponding to the models given in Annex III to the present Convention. If the language used is neither English nor French, the text shall include a translation into one of these languages.

Article 19

Duration and validity of certificates

(1) An International Load Line Certificate shall be issued for a period specified by the Administration, which shall not exceed 5 years.

(2)(a) Notwithstanding the requirements of paragraph (1), when the renewal survey is completed within 3 months before the expiry date of the existing certificate, the new certificate shall be valid from the date of completion of the renewal survey to a date not exceeding 5 years from the date of expiry of the existing certificate.

(2)(b) When the renewal survey is completed after the expiry date of the existing certificate, the new certificate shall be valid from the date of completion of the renewal survey to a date not exceeding 5 years from the date of expiry of the existing certificate.

(2)(c) When the renewal survey is completed more than 3 months before the expiry date of the existing certificate, the new certificate shall be valid from the date of completion of the renewal survey to a date not exceeding 5 years from the date of completion of the renewal survey.

(3) If a certificate is issued for a period of less than 5 years, the Administration may extend the validity of a certificate beyond the expiry date to the maximum period specified in paragraph (1), provided that the annual surveys referred to in article 14 applicable when a certificate is issued for a period of 5 years are carried out as appropriate.

(4) If, after the renewal survey referred to in paragraph (1)(b) of article 14, a new certificate cannot be issued to the ship before the expiry date of the existing certificate, the person or organisation carrying out the survey may extend the validity of the existing certificate for a period which shall not exceed 5 months. This extension shall be endorsed on the certificate, and shall be granted only where there have been no alterations in the structure, equipment, arrangements, materials or scantlings which affect the ship's freeboard.

(5) If a ship at the time when a certificate expires is not in a port in which it is to be surveyed, the Administration may extend the period of validity of the certificate but this extension shall be granted only for the purpose of allowing the ship to complete its voyage to the port in which it is to be surveyed, and then only in cases where it appears proper and reasonable to do so. No certificate shall be extended for a period longer than 3 months, and a ship to which an extension is granted shall not, on its arrival in the port in which it is to be surveyed, be entitled by virtue of such extension to leave that port without having a new certificate. When the renewal survey is completed, the new certificate shall be valid to a date not exceeding 5 years from the date of expiry of the existing certificate before the extension was granted.

(6) A certificate issued to a ship engaged on short voyages which has not been extended under the foregoing provisions of this article may be extended by the Administration for a period of grace of up to one month from the date of expiry stated on it. When the renewal survey is completed the new certificate shall be valid to a date not exceeding 5 years from the date of expiry of the existing certificate before the extension was granted.

(7) In special circumstances, as determined by the Administration, a new certificate need not be dated from the date of expiry of the existing certificate as required by paragraphs (2), (5) and (6). In these special

circumstances, the new certificate shall be valid to a date not exceeding 5 years from the date of completion of the renewal survey.

(8) If an annual survey is completed before the period specified in article 14 then:

(8)(a) the anniversary date shown on the certificate shall be amended by endorsement to a date which shall not be more than 3 months later than the date on which the survey was completed;

(8)(b) the subsequent annual survey required by article 14 shall be completed at the intervals prescribed by that article using the new anniversary date;

(8)(c) the expiry date may remain unchanged provided one or more annual surveys are carried out so that the maximum intervals between the surveys prescribed by article 14 are not exceeded.

(9) An International Load Line Certificate shall cease to be valid if any of the following circumstances exist:

(9)(a) material alterations have taken place in the hull or superstructures of the ship such as would necessitate the assignment of an increased freeboard;

(9)(b) the fittings and appliances mentioned in paragraph (1)(c) of article 14 are not maintained in an effective condition;

(9)(c) the certificate is not endorsed to show that the ship has been surveyed as provided in paragraph (1)(c) of article 14;

(9)(d) the structural strength of the ship is lowered to such an extent that the ship is unsafe.

(10)(a) The duration of an International Load Line Exemption Certificate issued by an Administration to a ship exempted under paragraph (2) of article 6 shall not exceed 5 years. Such certificate shall be subject to a renewal, endorsement, extension and cancellation procedure similar to that provided for an International Load Line Certificate under this article.

(10)(b) The duration of an International Load Line Exemption Certificate issued to a ship exempted under paragraph (4) of article 6 shall be limited to the single voyage for which it is issued.

(11) A certificate issued to a ship by an Administration shall cease to be valid upon the transfer of such a ship to the flag of another State.

Article 20

Acceptance of certificates

The certificates issued under the authority of a Contracting Government in accordance with the present Convention shall be accepted by the other Contracting Governments and regarded for all purposes covered by the present Convention as having the same force as certificates issued by them.

Article 21

Control

(1) Ships holding a certificate issued under Article 16 or Article 17 are subject, when in the ports of other Contracting Governments, to control by officers duly authorized by such Governments. Contracting Governments shall ensure that such control is exercised as far as is reasonable and practicable with a view to verifying that there is on board a valid certificate under the present Convention. If there is a valid International Load Line Certificate on board the ship, such control shall be limited to the purpose of determining that:

(1)(a) the ship is not loaded beyond the limits allowed by the certificate;

(1)(b) the position of the load line of the ship corresponds with the certificate;

(1)(c) the ship has not been so materially altered in respect of the matters set out in sub-paragraphs (a) and (b) of paragraph (9) of Article 19 that the ship is manifestly unfit to proceed to sea without danger to human life. If there is a valid International Load Line Exemption Certificate on board, such control shall be limited to the purpose of determining that any conditions stipulated in that certificate are complied with.

(2) If such control is exercised under sub-paragraph (c) of paragraph (1) of this Article, it shall only be exercised in so far as may be necessary to ensure that the ship shall not sail until it can proceed to sea without danger to the passengers or the crew.

(3) In the event of the control provided for in this Article giving rise to intervention of any kind, the officer carrying out the control shall immediately inform in writing the Consul or the diplomatic representative of the State whose flag the ship is flying of this decision and of all the circumstances in which intervention was deemed to be necessary.

Article 22

Privileges

The privileges of the present Convention may not be claimed in favour of any ship unless it holds a valid certificate under the Convention.

Article 23

Casualties

- (1) Each Administration undertakes to conduct an investigation of any casualty occurring to ships for which it is responsible and which are subject to the provisions of the present Convention when it judges that such an investigation may assist in determining what changes in the Convention might be desirable.
- (2) Each Contracting Government undertakes to supply the Organization with the pertinent information concerning the findings of such investigations. No reports or recommendations of the Organization based upon such information shall disclose the identity or nationality of the ships concerned or in any manner fix or imply responsibility upon any ship or person.

Article 24

Prior treaties and conventions

- (1) All other treaties, conventions and arrangements relating to load line matters at present in force between Governments Parties to the present Convention shall continue to have full and complete effect during the terms thereof as regards :
 - (1)(a) ships to which the present Convention does not apply; and
 - (1)(b) ships to which the present Convention applies, in respect of matters for which it has not expressly provided.
- (2) To the extent, however, that such treaties, conventions or arrangements conflict with the provisions of the present Convention, the provisions of the present Convention shall prevail.

Article 25

Special rules drawn up by agreement

When in accordance with the present Convention special rules are drawn up by agreement among all or some of the Contracting Governments, such rules shall be communicated to the Organization for circulation to all Contracting Governments.

Article 26

Communication of information

- (1) The Contracting Governments undertake to communicate to and deposit with the Organization :
 - (1)(a) a sufficient number of specimens of their certificates issued under the provisions of the present Convention for circulation to the Contracting Governments;
 - (1)(b) the text of the laws, decrees, orders, regulations and other instruments which shall have been promulgated on the various matters within the scope of the present Convention;
 - (1)(c) a list of non-governmental agencies which are authorized to act in their behalf in the administration of load line matters for circulation to the Contracting Governments.
- (2) Each Contracting Government agrees to make its strength standards available to any other Contracting Government, upon request.

Article 27

Signature, acceptance and accession

- (1) The present Convention shall remain open for signature for three months from 5 April 1966 and shall thereafter remain open for accession. Governments of States Members of the United Nations, or of any of the Specialized Agencies, or of the International Atomic Energy Agency, or parties to the Statute of the International Court of Justice may become parties to the Convention by:
 - (1)(a) signature without reservation as to acceptance;
 - (1)(b) signature subject to acceptance followed by acceptance; or
 - (1)(c) accession.
- (2) Acceptance or accession shall be effected by the deposit of an instrument of acceptance or accession with the Organization which shall inform all Governments that have signed the Convention or acceded to it of each new acceptance or accession and of the date of its deposit.

Article 28

Coming into force

- (1) The present Convention shall come into force twelve months after the date on which not less than fifteen governments of States, including seven each with not less than one million gross tonnage of shipping, have

signed without reservation as to acceptance or deposited instruments of acceptance or accession in accordance with Article 27. The Organization shall inform all Governments which have signed or acceded to the present Convention of the date on which it comes into force.

(2) For Governments which have deposited an instrument of acceptance of or accession to the present Convention during the twelve months mentioned in paragraph (1) of this Article, the acceptance or accession shall take effect on the coming into force of the present Convention or three months after the date of deposit of the instrument of acceptance or accession, whichever is the later date.

(3) For Governments which have deposited an instrument of acceptance of or accession to the present Convention after the date on which it comes into force, the Convention shall come into force three months after the date of the deposit of such instrument.

(4) After the date on which all the measures required to bring an amendment to the present Convention into force have been completed, or all necessary acceptances are deemed to have been given under sub-paragraph (b) of paragraph (2) of Article 29 in case of amendment by unanimous acceptance, any instrument of acceptance or accession deposited shall be deemed to apply to the Convention as amended.

Article 29

Amendments

(1) The present Convention may be amended upon the proposal of a Contracting Government by any of the procedures specified in this Article.

(2) Amendment by unanimous acceptance :

(2)(a) Upon the request of a Contracting Government, any amendment proposed by it to the present Convention shall be communicated by the Organization to all Contracting Governments for consideration with a view to unanimous acceptance.

(2)(b) Any such amendment shall enter into force twelve months after the date of its acceptance by all Contracting Governments unless an earlier date is agreed upon. A Contracting Government which does not communicate its acceptance or rejection of the amendment to the Organization within three years of its first communication by the latter shall be deemed to have accepted the amendment.

(2)(c) Any proposed amendment shall be deemed to be rejected if it is not accepted under sub-paragraph (b) of the present paragraph within three years after it has been first communicated to all Contracting Governments by the Organization.

(3) Amendment after consideration in the Organization:

(3)(a) Upon the request of a Contracting Government, any amendment proposed by it to the present Convention will be considered in the Organization. If adopted by a majority of two-thirds of those present and voting in the Maritime Safety Committee of the Organization, such amendment shall be communicated to all Members of the Organization and all Contracting Governments at least six months prior to its consideration by the Assembly of the Organization.

(3)(b) If adopted by a two-thirds majority of those present and voting in the Assembly, the amendment shall be communicated by the Organization to all Contracting Governments for their acceptance.

(3)(c) Such amendment shall come into force twelve months after the date on which it is accepted by two-thirds of the Contracting Governments. The amendment shall come into force with respect to all Contracting Governments except those which, before it comes into force, make a declaration that they do not accept the amendment.

(3)(d) The Assembly, by a two-thirds majority of those present and voting, including two-thirds of the Governments represented on the Maritime Safety Committee and present and voting in the Assembly, may propose a determination at the time of its adoption that an amendment is of such an important nature that any Contracting Government which makes a declaration under sub-paragraph (c), and which does not accept the amendment within a period of twelve months after it comes into force, shall cease to be a party to the present Convention upon the expiry of that period. This determination shall be subject to the prior acceptance of two-thirds of the Contracting Governments to the present Convention.

(3)(e) Nothing in this paragraph shall prevent the Contracting Government which first proposed action under this paragraph on an amendment to the present Convention from taking at any time such alternative action as it deems desirable in accordance with paragraph (2) or (4) of this Article.

(4) Amendment by a conference:

(4)(a) Upon the request of a Contracting Government, concurred in by at least one-third of the Contracting Governments, a conference of Governments will be convened by the Organization to consider amendments to the present Convention.

(4)(b) Every amendment adopted by such a conference by a two-thirds majority of those present and voting of the Contracting Governments shall be communicated by the Organization to all Contracting Governments for their acceptance.

(4)(c) Such amendment shall come into force twelve months after the date on which it is accepted by two-thirds of the Contracting Governments. The amendment shall come into force with respect to all Contracting Governments except those which, before it comes into force, make a declaration that they do not accept the amendment.

(4)(d) By a two-thirds majority of those present and voting, a conference convened under sub-paragraph (a) may determine at the time of its adoption that an amendment is of such an important nature that any Contracting Government which makes a declaration under sub-paragraph (c), and which does not accept the amendment within a period of twelve months after it comes into force, shall cease to be a party to the present Convention upon the expiry of that period.

(5) Any amendments to the present Convention made under this Article which relate to the structure of a ship shall apply only to ships the keels of which are laid, or which are at a similar stage of construction, on or after the date on which the amendment comes into force.

(6) The Organization shall inform all Contracting Governments of any amendments which come into force under this Article, together with the date on which each such amendment will come into force.

(7) Any acceptance or declaration under this Article shall be made by a notification in writing to the Organization which shall notify all Contracting Governments of the receipt of the acceptance or declaration.

Article 30

Denunciation

(1) The present Convention may be denounced by any Contracting Government at any time after the expiry of five years from the date on which the Convention comes into force for that Government.

(2) Denunciation shall be effected by a notification in writing addressed to the Organization which shall inform all the other Contracting Governments of any such notification received and of the date of its receipt.

(3) A denunciation shall take effect one year, or such longer period as may be specified in the notification, after its receipt by the Organization.

Article 31

Suspension

(1) In case of hostilities or other extraordinary circumstances which affect the vital interests of a State the Government of which is a Contracting Government, that Government may suspend the operation of the whole or any part of the present Convention. The suspending Government shall immediately give notice of any such suspension to the Organization.

(2) Such suspension shall not deprive other Contracting Governments of any right of control under the present Convention over the ships of the suspending Government when such ships are within their ports.

(3) The suspending Government may at any time terminate such suspension and shall immediately give notice of such termination to the Organization.

(4) The Organization shall notify all Contracting Governments of any suspension or termination of suspension under this Article.

Article 32

Territories

(1)(a) The United Nations, in cases where they are the administering authority for a territory, or any Contracting Government responsible for the international relations of a territory, shall as soon as possible consult with such territory in an endeavour to extend the present Convention to that territory and may at any time by notification in writing to the Organization declare that the present Convention shall extend to such territory.

(1)(b) The present Convention shall, from the date of the receipt of the notification or from such other date as may be specified in the notification, extend to the territory named therein.

(2)(a) The United Nations, or any Contracting Government which has made a declaration under sub-paragraph (a) of paragraph (1) of this Article, at any time after the expiry of a period of five years from the date on which the Convention has been so extended to any territory, may by notification in writing to the Organization declare that the present Convention shall cease to extend to any such territory named in the notification.

(2)(b) The present Convention shall cease to extend to any territory mentioned in such notification one year, or such longer period as may be specified therein, after the date of receipt of the notification by the Organization.

(3) The Organization shall inform all the Contracting Governments of the extension of the present Convention

to any territories under paragraph (1) of this Article, and of the termination of any such extension under the provisions of paragraph (2), stating in each case the date from which the present Convention has been or will cease to be so extended.

Article 33

Registration

(1) The present Convention shall be deposited with the Organization and the Secretary-General of the Organization shall transmit certified true copies thereof to all Signatory Governments and to all Governments which accede to the present Convention.

(2) As soon as the present Convention comes into force it shall be registered by the Organization in accordance with Article 102 of the Charter of the United Nations.

Article 34

Languages

The present Convention is established in a single copy in the English and French languages, both texts being equally authentic. Official translations in the Russian and Spanish languages shall be prepared and deposited with the signed original.

Annex 1

Regulations for determining load lines

Chapter I

General

The regulations assume that the nature and stowage of the cargo, ballast, etc., are such as to secure sufficient stability of the ship and the avoidance of excessive structural stress.

The regulations also assume that where there are international requirements relating to stability or subdivision, these requirements have been complied with.

Regulation 1 Strength and intact stability of ships

(1) The Administration shall satisfy itself that the general structural strength of the ship is adequate for the draught corresponding to the freeboard assigned.

(2) A ship which is designed, constructed and maintained in compliance with the appropriate requirements of an organization, including a classification society, which is recognized by the Administration or with applicable national standards of the Administration in accordance with the provisions of regulation 2-1, may be considered to provide an acceptable level of strength. The above provisions shall apply to all structures, equipment and fittings covered by this annex for which standards for strength and construction are not expressly provided.

(3) *Compliance*

(3)(a) Ships constructed before 1 July 2010 shall comply with an intact stability standard acceptable to the Administration.

(3)(b) Ships constructed on or after 1 July 2010 shall, as a minimum, comply with the requirements of part A of the 2008 IS Code.

Regulation 2 Application

(1) Ships with mechanical means of propulsion or lighters, barges or other ships without independent means of propulsion, shall be assigned freeboards in accordance with the provisions of regulations 1 to 40, inclusive.

(2) Ships carrying timber deck cargoes may be assigned, in addition to the freeboards prescribed in paragraph (1), timber freeboards in accordance with the provisions of regulations 41 to 45.

(3) Ships designed to carry sail, whether as the sole means of propulsion or as a supplementary means, and tugs, shall be assigned freeboards in accordance with the provisions of regulations 1 to 40, inclusive. Additional freeboard may be required as determined by the Administration.

(4) Ships of wood or of composite construction, or of other materials the use of which the Administration has approved, or ships whose constructional features are such as to render the application of the provisions of this Annex unreasonable or impracticable, shall be assigned freeboards as determined by the Administration.

(5) Regulations 10 to 26, inclusive, shall apply to every ship to which a minimum freeboard is assigned.

Relaxations from these requirements may be granted to a ship to which a greater than minimum freeboard is

assigned, on condition that the Administration is satisfied with the safety conditions provided.

(6) Where the assigned summer freeboard is increased such that the resulting draught is not more than that corresponding to a minimum summer freeboard for the same ship, but with an assumed freeboard deck located a distance below the actual freeboard deck at least equal to the standard superstructure height, the conditions of assignment in accordance with regulations 12,14-1 through 20, 23, 24 and 25, as applicable, to the actual freeboard deck may be as required for a superstructure deck.

(7) Unless expressly provided otherwise, the regulations of this Annex shall apply to ships the keels of which are laid or which are at a similar stage of construction on or after 1 January 2005.

(8) For ships the keels of which are laid or which are at a similar stage of construction before 1 January 2005, the Administration shall ensure that the requirements which are applicable under the International Convention on Load Lines, 1966, as modified by the Protocol of 1988 relating thereto, adopted by the International Conference on Harmonized System of Survey and Certification, 1988, are complied with.

(9) High-speed craft which comply with the requirements of the International Code of Safety for High-Speed Craft, 2000 (2000 HSC Code), adopted by the Maritime Safety Committee of the Organization by resolution MSC.97(73) and which have been surveyed and certified as provided in the Code shall be deemed to have complied with the requirements of this Annex. The certificates and permits issued under the 2000 HSC Code shall have the same force and the same recognition as the certificates issued under this Annex.

Regulation 2-1 Authorization of recognized organizations

The Administration¹⁾ shall authorize organizations, including classification societies, referred to in article 13 of the Convention and regulation 1(2) in accordance with the provisions of the present Convention and with the Code for Recognized Organizations (RO Code), consisting of part I and part 2 (the provisions of which shall be treated as mandatory) and part 3 (the provisions of which shall be treated as recommendatory), as adopted by the Organization by resolution MSC.349(92), as may be amended by the Organization, provided that:

(a) amendments to part 1 and part 2 of the RO Code are adopted, brought into force and take effect in accordance with the provisions of article VI of the present Protocol;

(b) amendments to part 3 of the RO Code are adopted by the Maritime Safety Committee in accordance with its Rules of Procedure; and

(c) any amendments adopted by the Maritime Safety Committee and the Marine Environment Protection Committee are identical and come into force or take effect at the same time, as appropriate.

Regulation 3 Definitions of terms used in the Annexes

(1) Length

(1)(a) The length (L) shall be taken as 96% of the total length on a waterline at 85% of the least moulded depth measured from the top of the keel, or as the length from the fore side of the stem to the axis of the rudder stock on that waterline, if that be greater.

(1)(b) For ships without a rudder stock, the length (L) is to be taken as 96% of the waterline at 85% of the least moulded depth.

(1)(c) Where the stem contour is concave above the waterline at 85% of the least moulded depth, both the forward terminal of the total length and the fore-side of the stem respectively shall be taken at the vertical projection to that waterline of the aftermost point of the stem contour (above that waterline) (see figure 3.1

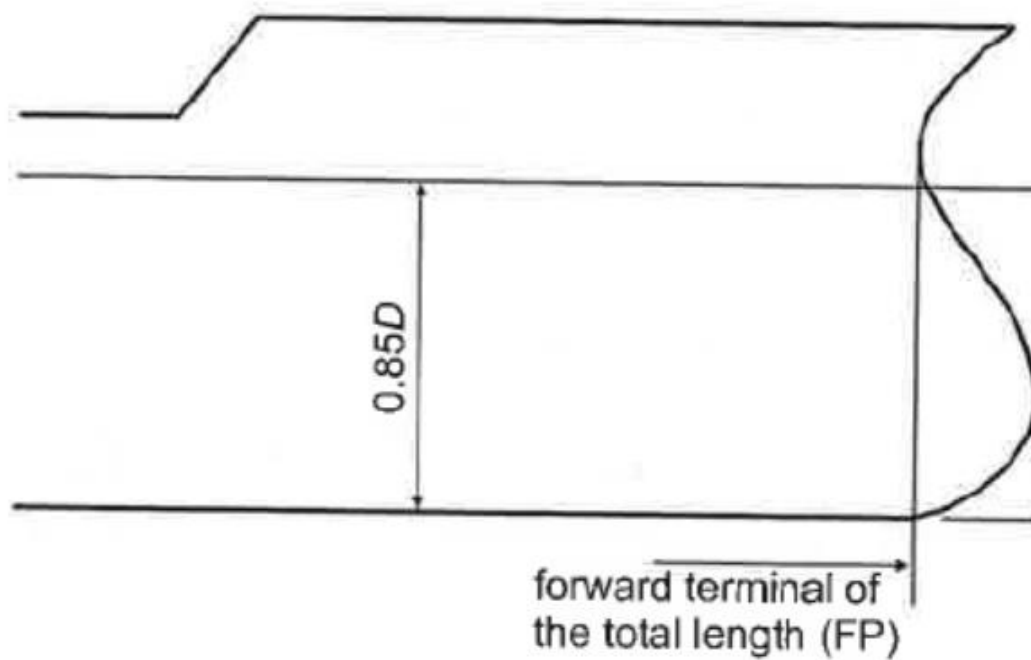

Figure 3.1

(1)(d) In ships designed with a rake of keel the waterline on which this length is measured shall be parallel to the designed waterline at 85% of the least moulded depth D_{min} , found by drawing a line parallel to the keel line of the vessel (including skeg) tangent to the moulded sheer line of the freeboard deck. The least moulded depth is the vertical distance measured from the top of the keel to the top of the freeboard deck beam at side at the point of tangency (see figure 3.2).

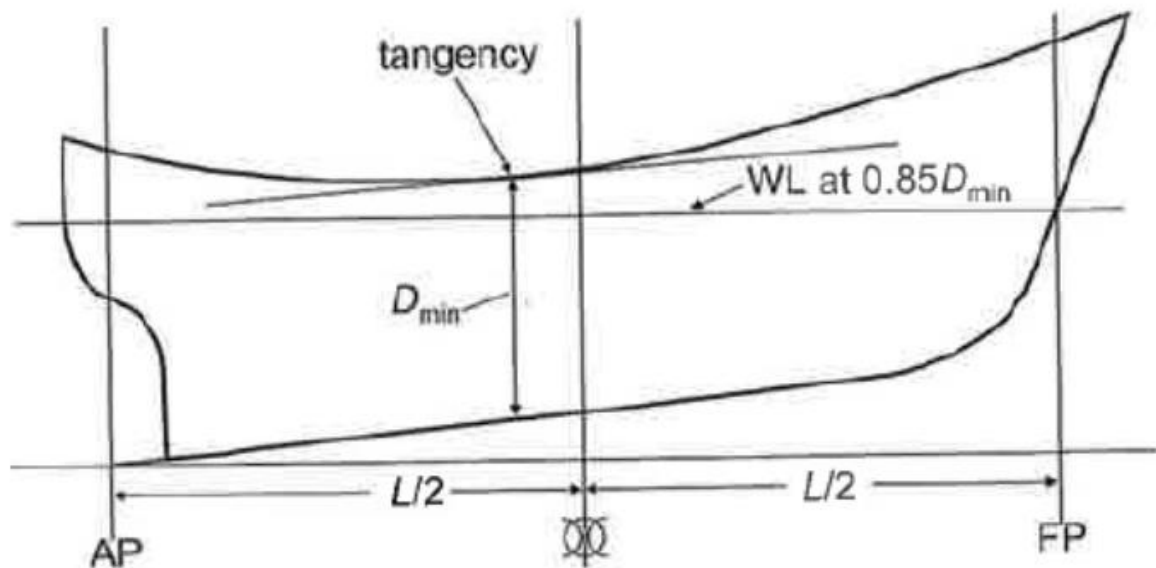

Figure 3.2

(2) Perpendiculars. The forward and after perpendiculars shall be taken at the forward and after ends of the length (L). The forward perpendicular shall coincide with the foreside of the stem on the waterline on which the length is measured.

(3) Amidships. Amidships is at the middle of the length (L).

(4) Breadth. Unless expressly provided otherwise, the breadth (B) is the maximum breadth of the ship, measured amidships to the moulded line of the frame in a ship with a metal shell and to the outer surface of the hull in a ship with a shell of any other material.

(5) Moulded depth

(5)(a) The moulded depth is the vertical distance measured from the top of the keel to the top of the freeboard deck beam at side. In wood and composite ships the distance is measured from the lower edge of the keel rabbet. Where the form at the lower part of the midship section is of a hollow character, or where thick garboards are fitted, the distance is measured from the point where the line of the flat of the bottom continued inwards cuts the side of the keel.

(5)(b) In ships having rounded gunwales, the moulded depth shall be measured to the point of intersection of the moulded lines of deck and sides, the lines extending as though the gunwale were of angular design.

(5)(c) Where the freeboard deck is stepped and the raised part of the deck extends over the point at which the moulded depth is to be determined, the moulded depth shall be measured to a line of reference extending from the lower part of the deck along a line parallel with the raised part.

(6) Depth for freeboard (D)

(6)(a) The depth for freeboard (D) is the moulded depth amidships, plus the freeboard deck thickness at side.

(6)(b) The depth for freeboard (D) in a ship having a rounded gunwale with a radius greater than 4% of the breadth (B) or having topsides of unusual form is the depth for freeboard of a ship having a midship section with vertical topsides and with the same round of beam and area of topside section equal to that provided by the actual midship section.

(7) Block coefficient

(7)(a) The block coefficient (C_b) is given by:

$$C_b = \nabla / (L \times B \times d_1); \text{ where}$$

∇ d_1 is 85% of the least moulded depth.

(7)(b) When calculating the block coefficient of a multi-hull craft, the full breadth (B) as defined in paragraph (4) is to be used and not the breadth of a single hull.

(8) Freeboard. The freeboard assigned is the distance measured vertically downwards amidships from the upper edge of the deck line to the upper edge of the related load line.

(9) Freeboard deck.

(9)(a) The freeboard deck is normally the uppermost complete deck exposed to weather and sea, which has

permanent means of closing all openings in the weather part thereof, and below which all openings in the sides of the ship are fitted with permanent means of watertight closing.

(9)(b) Lower deck as a freeboard deck

At the option of the owner and subject to the approval of the Administration, a lower deck may be designated as the freeboard deck provided it is a complete and permanent deck continuous in a fore and aft direction at least between the machinery space and peak bulkheads and continuous athwartships.

(9)(b)(i) When this lower deck is stepped the lowest line of the deck and the continuation of that line parallel to the upper part of the deck is taken as the freeboard deck.

(9)(b)(ii) When a lower deck is designated as the freeboard deck, that part of the hull which extends above the freeboard deck is treated as a superstructure so far as concerns the application of the conditions of assignment and the calculation of freeboard. It is from this deck that the freeboard is calculated.

(9)(b)(iii) When a lower deck is designated as the freeboard deck, such deck as a minimum shall consist of suitably framed stringers at the ship sides and transversely at each watertight bulkhead which extends to the upper deck, within cargo spaces. The width of these stringers shall not be less than can be conveniently fitted having regard to the structure and the operation of the ship. Any arrangement of stringers shall be such that structural requirement can also be met.

(9)(c) Discontinuous freeboard deck, stepped freeboard deck.

(9)(c)(i) Where a recess in the freeboard deck extends to the sides of the ship and is in excess of one metre in length, the lowest line of the exposed deck and the continuation of that line parallel to the upper part of the deck is taken as the freeboard deck (see figure 3.3).

(9)(c)(ii) Where a recess in the freeboard deck does not extend to the sides of the ship, the upper part of the deck is taken as the freeboard deck.

(9)(c)(iii) Recesses not extending from side to side in a deck below the exposed deck, designated as the freeboard deck, may be disregarded, provided all openings in the weather deck are fitted with weathertight closing appliances.

(9)(c)(iv) Due regard shall be given to the drainage of exposed recesses and to free surface effects on stability.

(9)(c)(v) Provisions of subparagraphs (i) through (iv) are not intended to apply to dredgers, hopper barges or other similar types of ships with large open holds, where each case requires individual consideration.

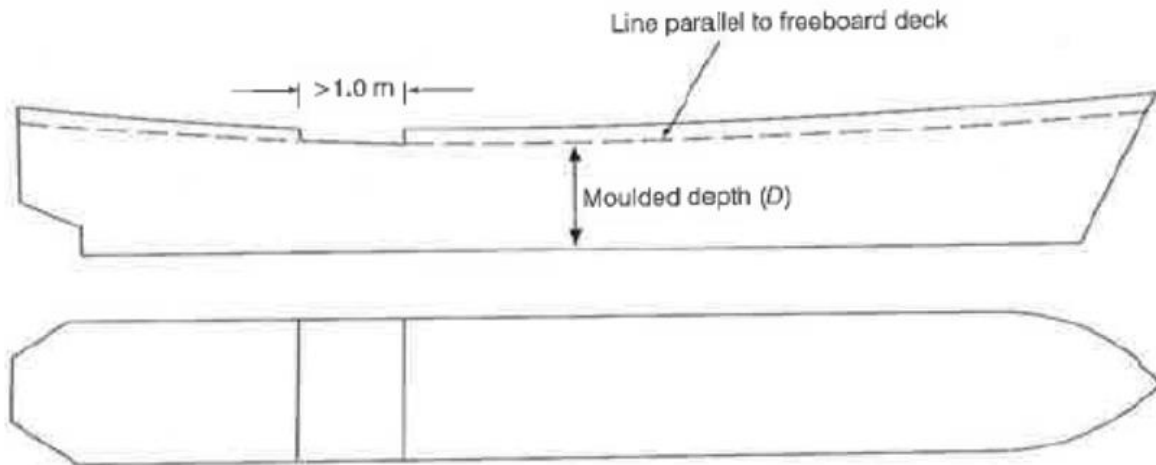

Figure 3.3

(10) Superstructure

(10)(a) A superstructure is a decked structure on the freeboard deck, extending from side to side of the ship or with the side plating not being inboard of the shell plating more than 4% of the breadth (B).

(10)(b) An enclosed superstructure is a superstructure with:

(10)(b)(i) enclosing bulkheads of efficient construction;

(10)(b)(ii) access openings, if any, in these bulkheads fitted with doors complying with the requirements of regulation 12;

(10)(b)(iii) all other openings in sides or ends of the superstructure fitted with efficient weathertight means of closing.

A bridge or poop shall not be regarded as enclosed unless access is provided for the crew starting from any point on the uppermost complete exposed deck or higher to reach machinery and other working spaces inside these superstructures by alternative means which are available at all times when bulkhead openings are closed.

(10)(c) The height of a superstructure is the least vertical height measured at side from the top of the superstructure deck beams to the top of the freeboard deck beams.

(10)(d) The length of a superstructure (S) is the mean length of the part of the superstructure which lies within the length (L).

(10)(e) Bridge. A bridge is a superstructure which does not extend to either the forward or after perpendicular.

(10)(f) Poop. A poop is a superstructure which extends from the after perpendicular forward to a point which is aft of the forward perpendicular. The poop may originate from a point aft of the aft perpendicular.

(10)(g) Forecastle. A forecastle is a superstructure which extends from the forward perpendicular aft to a point which is forward of the after perpendicular. The forecastle may originate from a point forward of the forward perpendicular.

(10)(h) Full superstructure. A full superstructure is a superstructure which, as a minimum, extends from the

forward to the after perpendicular.

(10)(i) Raised quarterdeck. A raised quarterdeck is a superstructure which extends forward from the after perpendicular, generally has a height less than a normal superstructure, and has an intact front bulkhead (sidescuttles of the non-opening type fitted with efficient deadlights and bolted man hole covers) (see figure 3.4). Where the forward bulkhead is not intact due to doors and access openings, the superstructure is then to be considered as a poop.

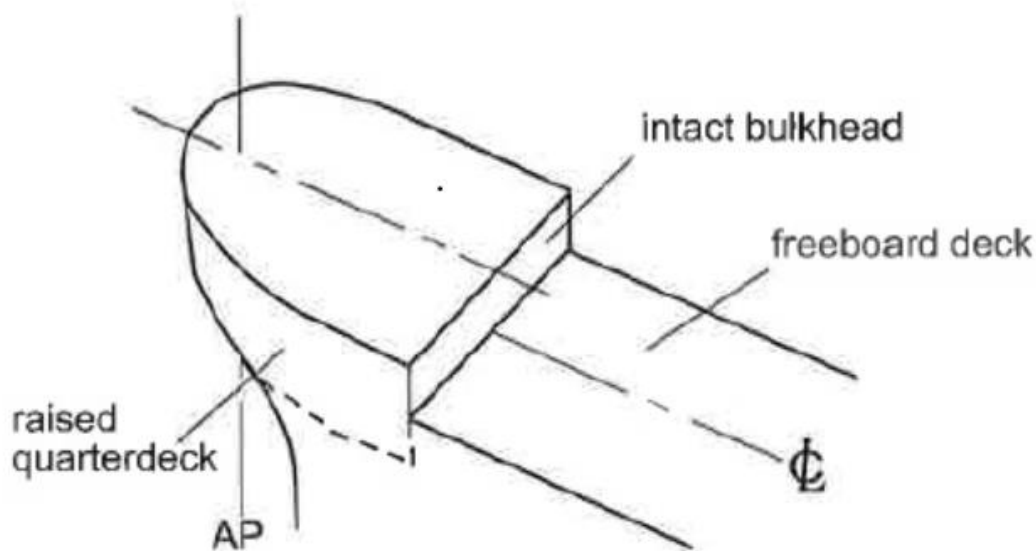

Figure 3.4

(11) Superstructure deck. A superstructure deck is a deck forming the upper boundary of a superstructure.

(12) Flush deck ship. A flush deck ship is one which has no superstructure on the freeboard deck.

(13) Weathertight. Weathertight means that in any sea conditions water will not penetrate into the ship.

(14) Watertight. Watertight means capable of preventing the passage of water through the structure in either direction with a proper margin of resistance under the pressure due to the maximum head of water which it might have to sustain.

(15) Well. A well is any area on the deck exposed to the weather, where water may be entrapped. Wells are considered to be deck areas bounded on two or more sides by deck structures.

(16) *2008 IS Code* means the International Code on Intact Stability, 2008, consisting of an introduction, part A (the provisions of which shall be treated as mandatory) and part B (the provisions of which shall be treated as recommendatory).

(17) *Audit* means a systematic, independent and documented process for obtaining audit evidence and evaluating it objectively to determine the extent to which audit criteria are fulfilled.

(18) *Audit Scheme* means the IMO Member State Audit Scheme established by the Organization and taking into account the guidelines developed by the Organizationⁱⁱ⁾

(19) *Code for Implementation* means the IMO Instruments Implementation Code (III Code) adopted by the Organization by resolution A. 1070(28)

(20) *Audit Standard* means the Code for Implementation.

Regulation 4 Deck line

The deck line is a horizontal line 300 mm in length and 25 mm in breadth. It shall be marked amidships on each side of the ship, and its upper edge shall normally pass through the point where the continuation outwards of the upper surface of the freeboard deck intersects the outer surface of the shell (as illustrated in figure 4.1), provided that the deck line may be placed with reference to another fixed point on the ship on condition that the freeboard is correspondingly corrected. The location of the reference point and the identification of the freeboard deck shall in all cases be indicated on the International Load Line Certificate.

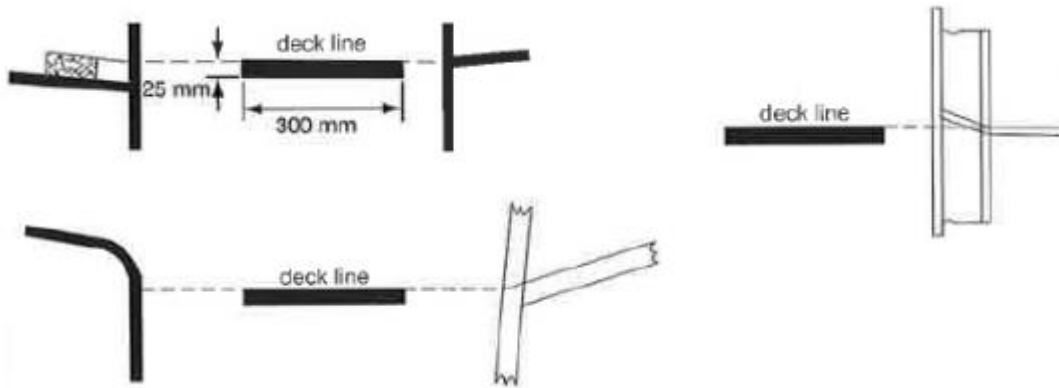

Regulation 5 Load line mark

The load line mark shall consist of a ring 300 mm in outside diameter and 25 mm wide which is intersected by a horizontal line 450 mm in length and 25 mm in breadth, the upper edge of which passes through the centre of the ring. The centre of the ring shall be placed amidships and at a distance equal to the assigned summer freeboard measured vertically below the upper edge of the deck line (as illustrated in figure 6.1).

Regulation 6 Lines to be used with the load line mark

(1) The lines which indicate the load line assigned in accordance with these regulations shall be horizontal lines 230 mm in length and 25 mm in breadth which extend forward of, unless expressly provided otherwise, and at right angles to, a vertical line 25 mm in breadth marked at a distance 540 mm forward of the centre of the ring (as illustrated in figure 6.1).

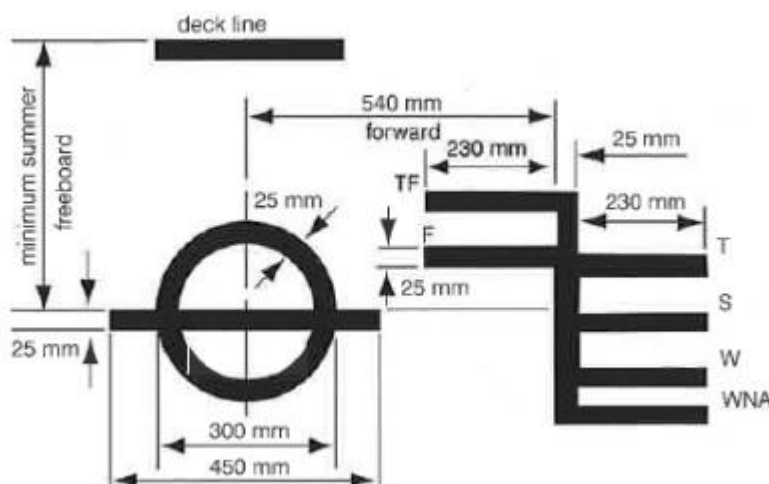

Figure 6.1

(2) The following load lines shall be used:

(2)(a) The Summer Load Line indicated by the upper edge of the line which passes through the centre of the ring and also by a line marked S.

(2)(b) The Winter Load Line indicated by the upper edge of a line marked W.

- (2)(c) The Winter North Atlantic Load Line indicated by the upper edge of a line marked WNA.
- (2)(d) The Tropical Load Line indicated by the upper edge of a line marked T.
- (2)(e) The Fresh Water Load Line in summer indicated by the upper edge of a line marked F. The Fresh Water Load Line in summer is marked abaft the vertical line. The difference between the Fresh Water Load Line in summer and the Summer Load Line is the allowance to be made for loading in fresh water at the other load lines.
- (2)(f) The Tropical Fresh Water Load Line indicated by the upper edge of a line marked TF and marked abaft the vertical line.
- (3) If timber freeboards are assigned in accordance with these regulations, the timber load lines shall be marked in addition to ordinary load lines. These lines shall be horizontal lines 230 mm in length and 25 mm in breadth which extend abaft unless expressly provided otherwise, and are at right angles to, a vertical line 25 mm in breadth marked at a distance 540 mm abaft the centre of the ring (as illustrated in figure 6.2).

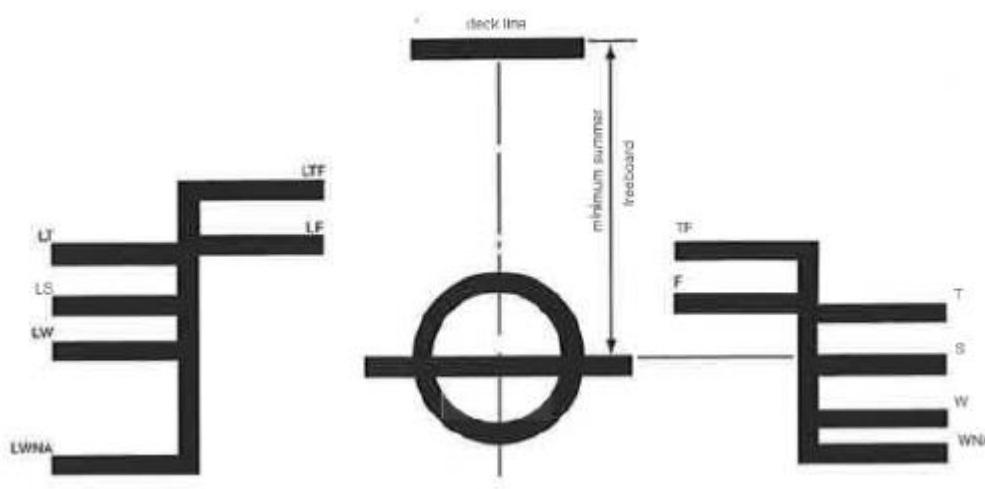

Figure 6.2

- (4) The following timber load lines shall be used:
- (4)(a) The Summer Timber Load Line indicated by the upper edge of a line marked LS.
- (4)(b) The Winter Timber Load Line indicated by the upper edge of a line marked LW.
- (4)(c) The Winter North Atlantic Timber Load Line indicated by the upper edge of a line marked LWNA.
- (4)(d) The Tropical Timber Load Line indicated by the upper edge of a line marked LT.
- (4)(e) The Fresh Water Timber Load Line in summer indicated by the upper edge of a line marked LF and marked forward of the vertical line. The difference between the Fresh Water Timber Load Line in summer and the Summer Timber Load Line is the allowance to be made for loading in fresh water at the other timber load lines.
- (4)(f) The Tropical Fresh Water Timber Load Line indicated by the upper edge of a line marked LTF and marked forward of the vertical line.
- (5) Where the characteristics of a ship or the nature of the ship's service or navigational limits make any of the seasonal lines inapplicable, these lines may be omitted.
- (6) Where a ship is assigned a greater than minimum freeboard so that the load line is marked at a position corresponding to, or lower than, the lowest seasonal load line assigned at minimum freeboard in accordance with the present Protocol, only the Fresh Water Load Line need be marked.
- (7) Where a Winter North Atlantic Load Line is identical with the Winter Load Line corresponding to the same vertical line, this load line shall be marked W.
- (8) Alternative/additional load lines required by other international conventions in force may be marked at right angles to and abaft the vertical line specified in paragraph (1).

Regulation 7 Mark of assigning authority

The mark of the Authority by whom the load lines are assigned may be indicated alongside the load line ring above the horizontal line which passes through the centre of the ring, or above and below it. This mark shall consist of not more than four initials to identify the Authority's name, each measuring approximately 115 mm

in height and 75 mm in width.

Regulation 8 Details of marking

The ring, lines and letters shall be painted in white or yellow on a dark ground or in black on a light ground. They shall also be permanently marked on the sides of the ships to the satisfaction of the Administration. The marks shall be plainly visible and, if necessary, special arrangements shall be made for this purpose.

Regulation 9 Verification of marks

The International Load Line Certificate shall not be delivered to the ship until the officer or surveyor acting under the provisions of article 13 of the Convention has certified that the marks are correctly and permanently indicated on the ship's sides.

Annex 1

Regulations for determining load lines

Chapter II

Conditions of assignment of freeboard

Regulation 10 Information to be supplied to the master

(1) The master of every new ship shall be supplied with information to arrange for the loading and ballasting of his ship in such a way as to avoid the creation of any unacceptable stresses in the ship's structure, provided that this requirement need not apply to any particular length, design or class of ship where the Administration considers it to be unnecessary.

(2) Information shall be provided to the master in a form that is approved by the Administration or a recognised organization. Stability information, and loading information also related to ship strength when required under paragraph (1), shall be carried on board at all times together with evidence that the information has been approved by the Administration.

(3) A ship which is not required under the International Convention for Safety of Life at Sea in force to undergo an inclining test upon its completion shall:

(3)(a) be so inclined and the actual displacement and position of the centre of gravity shall be determined for the lightship condition;

(3)(b) if the Administration so approves, have its inclining test on completion dispensed with, provided basic stability data are available from the inclining test of a sister ship and it is shown to the satisfaction of the Administration that reliable stability information for the ship can be obtained from such basic data;

(3)(c) if the Administration decides that the performance of an inclining experiment is not practicable or safe or yields inaccurate results due to the specific proportions, arrangements, strength or hull form of a ship, have the ship's lightship characteristics determined by a detailed weight estimate confirmed by a lightweight survey;

(3)(d) have such informationⁱⁱⁱ⁾ supplied for the use of its master as is necessary to enable the master, by rapid and simple processes, to obtain accurate guidance as to the stability of the ship under all conditions likely to be encountered in normal service; and

(3)(e) carry on board at all times its approved stability information together with evidence that the information has been approved by the Administration.

(4) Where any alterations are made to a ship so as to materially affect the loading or stability information supplied to the master, amended information shall be provided. If necessary the ship shall be re-inclined.

Regulation 11 Superstructure end bulkheads

Bulkheads at exposed ends of enclosed superstructures shall be of an acceptable level of strength.

Regulation 12 Doors

(1) All access openings in bulkheads at ends of enclosed superstructures shall be fitted with doors of steel or other equivalent material, permanently and strongly attached to the bulkhead, and framed, stiffened and fitted so that the whole structure is of equivalent strength to the un-pierced bulkhead and weathertight when closed. The means for securing these doors weathertight shall consist of gaskets and clamping devices or other equivalent means and shall be permanently attached to the bulkhead or to the doors themselves, and the doors shall be so arranged that they can be operated from both sides of the bulkhead.

(2) Unless otherwise permitted by the Administration, doors shall open outwards to provide additional

security against the impact of the sea.

(3) Except as otherwise provided in these regulations, the height of the sills of access openings in bulkheads at ends of enclosed superstructures shall be at least 380 mm above the deck.

(4) Portable sills shall be avoided. However, in order to facilitate the loading/unloading of heavy spare parts or similar, portable sills may be fitted on the following conditions:

(4)(a) they shall be installed before the ship leaves port; and

(4)(b) they shall be gasketed and fastened by closely spaced through bolts.

Regulation 13 Position of hatchways, doorways and ventilators

For the purpose of these regulations, two positions of hatchways, doorways and ventilators are defined as follows:

Position 1 - Upon exposed freeboard and raised quarter decks, and upon exposed superstructure decks situated forward of a point located a quarter of the ship's length from the forward perpendicular.

Position 2 - Upon exposed superstructure decks situated abaft a quarter of the ship's length from the forward perpendicular and located at least one standard height of superstructure above the freeboard deck.

Upon exposed superstructure decks situated forward of a point located a quarter of the ship's length from the forward perpendicular and located at least two standard heights of superstructure above the freeboard deck.

Regulation 14 Cargo and other hatchways

(1) The construction and means for securing the weathertightness of cargo and other hatchways in position 1 and 2 shall be at least equivalent to the requirements of regulation 16, unless the application of regulation 15 to such hatchways is granted by the Administration.

(2) Coamings and hatchway covers to exposed hatchways on decks above the superstructure deck shall comply with the requirements of the Administration.

Regulation 14-1 Hatchway coamings

(1) The coamings of hatchways shall be of substantial construction in accordance with their position, and their height above the deck shall be at least as follows:

(1)(a) 600 mm if in position 1; and

(1)(b) 450 mm if in position 2.

(2) In the case of hatchways which comply with regulation 16(2) through 16(5), the height of these coamings may be reduced, or the coamings omitted entirely, on condition that the Administration is satisfied that the safety of the ship is not thereby impaired in any sea conditions.

Regulation 15 Hatchways closed by portable covers and secured weathertight by tarpaulins and battening devices

Hatchway covers

(1) The width of each bearing surface for hatchway covers shall be at least 65 mm.

(2) Where covers are made of wood, the finished thickness shall be at least 60 mm in association with a span of not more than 1.5 m.

(3) Where covers are made of mild steel the strength shall be calculated in accordance with the requirement of regulation 16(2) to 16(4) and the product of the maximum stress thus calculated and the factor 1.25 shall not exceed the minimum upper yield point strength of the material. They shall be so designed as to limit the deflection to not more than 0.0056 times the span under these loads.

Portable beams

(4) Where portable beams for supporting hatchway covers are made of mild steel, the strength shall be calculated with assumed loads not less than 3.5 t/m² on hatchways in position 1 and not less than 2.6 t/m² on hatchways in position 2 and the product of the maximum stress thus calculated and the factor 1.47 shall not exceed the minimum upper yield point strength of the material. They shall be so designed as to limit the deflection to not more than 0.0044 times the span under these loads.

(5) The assumed loads on hatchways in position 1 may be reduced to 2 t/m² for ships 24 m in length and shall be not less than 3.5 t/m² for ships 100 m in length. The corresponding loads on hatchways in position 2 may be reduced to 1.5 t/m² and 2.6 t/m², respectively. In all cases, values at intermediate lengths shall be obtained by linear interpolation.

Pontoon covers

(6) Where pontoon covers used in place of portable beams and covers are made of mild steel, the strength shall be calculated in accordance with the requirement of regulation 16(2) to 16(4) and the product of the maximum stress thus calculated and the factor 1.47 shall not exceed the minimum upper yield point strength of the material. They shall be so designed as to limit the deflection to not more than 0.0044 times the span. Mild steel plating forming the tops of covers shall be not less in thickness than 1% of the spacing of stiffeners or 6 mm if that be greater.

(7) The strength and stiffness of covers made of materials other than mild steel shall be equivalent to those of mild steel to the satisfaction of the Administration.

Carriers or sockets

(8) Carriers or sockets for portable beams shall be of substantial construction, and shall provide means for the efficient fitting and securing of the beams. Where rolling types of beams are used, the arrangements shall ensure that the beams remain properly in position when the hatchway is closed.

Cleats

(9) Cleats shall be set to fit the taper of the wedges. They shall be at least 65 mm wide and spaced not more than 600 mm centre to centre; the cleats along each side or end shall be not more than 150 mm from the hatch corners.

Battens and wedges

(10) Battens and wedges shall be efficient and in good condition. Wedges shall be of tough wood or other equivalent material. They shall have a taper of not more than 1 in 6 and shall be not less than 13 mm thick at the toes.

Tarpaulins

(11) At least two layers of tarpaulin in good condition shall be provided for each hatchway in position 1 or 2. The tarpaulins shall be waterproof and of ample strength. They shall be of a material of at least an approved standard weight and quality.

Securing of hatchway covers

(12) For all hatchways in position 1 or 2 steel bars or other equivalent means shall be provided in order efficiently and independently to secure each section of hatchway covers after the tarpaulins are battened down. Hatchway covers of more than 1.5 m in length shall be secured by at least two such securing appliances.

Regulation 16 Hatchways closed by weathertight covers of steel or other equivalent materials

(1) All hatchways in position 1 and 2 shall be fitted with hatch covers of steel or other equivalent material. Except as provided in regulation 14(2), such covers shall be weathertight and fitted with gaskets and clamping devices. The means for securing and maintaining weathertightness shall be to the satisfaction of the Administration. The arrangements shall ensure that the tightness can be maintained in any sea conditions, and for this purpose tests for tightness shall be required at the initial survey, and may be required at renewal and annual surveys or at more frequent intervals.

Hatch cover minimum design loads

(2) For ships of 100 m in length and above:

(2)(a) Position 1 hatch covers located in the forward quarter of the ship's length shall be designed for wave loads at the forward perpendicular, calculated from the following equation:

$$\text{Load} = 5 + (L_H - 100) \times a \quad \text{in t/m}^2$$

where :

L_H is L for ships of not more than 340 m and equal to 340 m for ships of more than 340 m in length;

L is the length of the ship (meters), as defined in regulation 3;

a is given in table 16.1,

and reduced linearly to 3.5 t/m² at the end of the forward quarter's length, as shown in table 16.2. The design load used for each hatch cover panel shall be that determined at its midpoint location.

(2)(b) All other position 1 hatch covers shall be designed to 3.5 t/m².

(2)(c) Position 2 hatch covers shall be designed to 2.6 t/m².

(2)(d) Where a position 1 hatchway is located at least one superstructure standard height higher than the freeboard deck, it may be designed to 3.5 t/m².

Table 16.1

	<i>a</i>
Type B freeboard ships	0.0074
Ships assigned reduced freeboard by regulation 27(9) or (10)	0.0363

(3) For ships 24 m in length:

(3)(a) Position 1 hatch covers located in the forward quarter of the ship's length shall be designed for wave loads of 2.43 t/m² at the forward perpendicular and reduced linearly to 2 t/m² at the end of the forward quarter's length as shown in table 16.2. The design load used for each hatch cover panel shall be that determined at its midpoint location.

(3)(b) All other position 1 hatch covers shall be designed to 2 t/m².

(3)(c) Position 2 hatch covers shall be designed to 1.5 t/m².

(3)(d) Where a position 1 hatchway is located at least one superstructure standard height higher than the freeboard deck, it may be designed to 2 t/m².

(4) For ships between 24 m and 100 m in length, and for positions between *FP* and 0.25*L*, wave loads shall be obtained by linear interpolation of the values shown in table 16.2.

Table 16.2

	Longitudinal position		
	<i>FP</i>	0.25 <i>L</i>	Aft of 0.25 <i>L</i>
<i>L</i> > 100 m			
Freeboard deck	Equation in 16(2)(a)	3.5 t/m ²	3.5 t/m ²
Superstructure deck	3.5 t/m ²		2.6 t/m ²
<i>L</i> = 100 m			

Freeboard deck	5 t/m ²	3.5t/m ²	3.5 t/m ²
Superstructure deck	3.5 t/m ²		2.6 t/m ²
<i>L = 24 m</i>			
Freeboard deck	2.43 t/m ²	2 t/m ²	2 t/m ²
Superstructure deck	2 t/m ²	2 t/m ²	1.5 t/m ²

(5) All hatch covers shall be designed such that:

(5)(a) the product of the maximum stress determined in accordance with the above loads and the factor of 1.25 does not exceed the minimum upper yield point strength of the material in tension and the critical buckling strength in compression;

(5)(b) the deflection is limited to not more than 0.0056 times the span;

(5)(c) steel plating forming the tops of covers is not less in thickness than 1% of the spacing of stiffeners or 6 mm if that be greater; and

(5)(d) an appropriate corrosion margin is incorporated.

Securing arrangements

(6) The means for securing and maintaining weathertightness by other means than gaskets and clamping shall be to the satisfaction of the Administration.

(7) Hatch covers which rest on coamings shall be located in their closed position by means capable of withstanding horizontally acting loads in any sea conditions.

Regulation 17 Machinery space openings

(1) Machinery space openings in position 1 or 2 shall be properly framed and efficiently enclosed by steel casings of ample strength, and where the casings are not protected by other structures their strength shall be specially considered. Access openings in such casings shall be fitted with doors complying with the requirements of regulation 12(1), the sills of which shall be at least 600 mm above the deck if in position 1, and at least 380 mm above the deck if in position 2. Other openings in such casings shall be fitted with equivalent covers, permanently attached in their proper positions.

(2) Where machinery casings are not protected by other structures, double doors (i.e. inner and outer doors complying with the requirements of regulation 12(1)) shall be required for ships assigned freeboards less than those based on table 28.2 of regulation 28. An inner sill of 230 mm in conjunction with the outer sill of 600 mm shall be provided.

(3) Coamings of any fiddley, funnel or machinery space ventilator in an exposed position on the freeboard deck or superstructure deck shall be as high above the deck as is reasonable and practicable. In general, ventilators necessary to continuously supply the machinery space shall have coamings of sufficient height to comply with regulation 19(3), without having to fit weathertight closing appliances. Ventilators necessary to continuously supply the emergency generator room, if this is considered buoyant in the stability calculation or protecting opening leading below, shall have coamings of sufficient height to comply with regulation 19(3), without having to fit weathertight closing appliances.

(4) Where due to ship size and arrangement this is not practicable, lesser heights for machinery space and emergency generator room ventilator coamings, fitted with weathertight closing appliances in accordance with regulation 19(4), may be permitted by the Administration in combination with other suitable arrangements to ensure an uninterrupted, adequate supply of ventilation to these spaces.

(5) Fiddley openings shall be fitted with strong covers of steel or other equivalent material permanently attached in their proper positions and capable of being secured weathertight.

Regulation 18 Miscellaneous openings in freeboard and superstructure decks

(1) Manholes and flush scuttles in position 1 or 2 or within superstructures other than enclosed superstructures shall be closed by substantial covers capable of being made watertight. Unless secured by closely spaced bolts, the covers shall be permanently attached.

(2) Openings in freeboard decks other than hatchways, machinery space openings, manholes and flush scuttles shall be protected by an enclosed superstructure, or by a deckhouse or companionway of equivalent strength and weathertightness. Similarly, any such opening in an exposed superstructure deck, in the top of a deckhouse on the freeboard deck which gives access to a space below the freeboard deck or a space within an enclosed superstructure shall be protected by an efficient deckhouse or companionway. Doorways in such

companionways or deckhouses that lead or give access to stairways leading below, shall be fitted with doors in accordance with regulation 12.(1). Alternatively, if stairways within a deckhouse are enclosed within properly constructed companionways fitted with doors complying with regulation 12(1), the external door need not be weathertight.

(3) Openings in the top of a deckhouse on a raised quarterdeck or superstructure of less than standard height, having a height equal to or greater than the standard quarterdeck height, shall be provided with an acceptable means of closing but need not be protected by an efficient deckhouse or companionway as defined in the regulation, provided that the height of the deckhouse is at least the standard height of a superstructure. Openings in the top of the deck house on a deck house of less than a standard superstructure height may be treated in a similar manner.

(4) In position 1 the height above the deck of sills to the doorways in companionways shall be at least 600 mm. In position 2 it shall be at least 380 mm.

(5) Where access is provided from the deck above as an alternative to access from the freeboard deck in accordance with regulation 3(10)(b), then the height of sills into a bridge or poop shall be 380 mm. The same shall apply to deckhouses on the freeboard deck.

(6) Where access is not provided from above, the height of the sills to doorways in deckhouses on the freeboard deck shall be 600 mm.

(7) Where the closing appliances of access openings in superstructures and deckhouses are not in accordance with regulation 12(1), interior deck openings shall be considered exposed (i.e. situated in the open deck).

Regulation 19 Ventilators

(1) Ventilators in position 1 or 2 to spaces below freeboard deck or decks of enclosed superstructures shall have coamings of steel or other equivalent material, substantially constructed and efficiently connected to the deck. Ventilators in position 1 shall have coamings of a height of at least 900 mm above the deck; in position 2 the coamings shall be of a height at least 760 mm above the deck. Where the coaming of any ventilator exceeds 900 mm in height it shall be specially supported.

(2) Ventilators passing through superstructures other than enclosed superstructures shall have substantially constructed coamings of steel or other equivalent material at the freeboard deck.

(3) Ventilators in position 1 the coamings of which extend to more than 4.5 m above the deck, and in position 2 the coamings of which extend to more than 2.3 m above the deck, need not be fitted with closing arrangements unless specifically required by the Administration.

(4) Except as provided in paragraph (3), ventilator openings shall be provided with weathertight closing appliances of steel or other equivalent material. In ships of not more than 100 m in length the closing appliances shall be permanently attached; where not so provided in other ships, they shall be conveniently stowed near the ventilators to which they are to be fitted.

(5) In exposed locations, the height of coamings may be increased to the satisfaction of the Administration.

Regulation 20 Air pipes

(1) Where air pipes to ballast and other tanks extend above the freeboard or superstructure decks, the exposed parts of the pipes shall be of substantial construction; the height from the deck to the point where water may have access below shall be at least 760 mm on the freeboard deck and 450 mm on the superstructure deck.

(2) Where these heights may interfere with the working of the ship, a lower height may be approved, provided that the Administration is satisfied that the closing arrangements and other circumstances justify a lower height.

(3) Air pipes shall be provided with automatic closing devices.

(4) Pressure-vacuum valves (PV valves) may be accepted on tankers.

Regulation 21 Cargo ports and other similar openings

(1) Cargo ports and other similar openings in the sides of ships below the freeboard deck shall be fitted with doors so designed as to ensure the same watertightness and structural integrity as the surrounding shell plating. Unless otherwise granted by the Administration, these opening shall open outwards. The number of such openings shall be the minimum compatible with the design and proper working of the ship.

(2) Unless otherwise permitted by the Administration, the lower edge of openings referred to in paragraph (1) shall not be below a line drawn parallel to the freeboard deck at side, which is at its lowest point at least 230 mm above the upper edge of the uppermost load line.

(3) Where it is permitted to arrange cargo ports and other similar openings with their lower edge below the line specified in paragraph (2), additional features shall be fitted to maintain the watertight integrity.

(4) The fitting of a second door of equivalent strength and watertightness is one acceptable arrangement. A leakage detection device shall be provided in the compartment between the two doors. Drainage of this

compartment to the bilges, controlled by a readily accessible screw down valve, shall be arranged. The outer door shall open outwards.

(5) Arrangements for bow doors and their inner doors, side doors and stern doors and their securings shall be in compliance with the requirements of a recognised organization, or with the applicable national standards of the Administration which provide an equivalent level of safety.

Regulation 22 Scuppers, inlets and discharges

(1)(a) Discharges led through the shell either from spaces below the freeboard deck or from within superstructures and deckhouses on the freeboard deck fitted with doors complying with the requirements of regulation 12 shall, except as provided in paragraph (2), be fitted with efficient and accessible means for preventing water from passing inboard. Normally each separate discharge shall have one automatic non-return valve with a positive means of closing it from a position above the freeboard deck. Where the inboard end of the discharge pipe is located at least 0.01L above the Summer Load Line, the discharge may have two automatic non-return valves without positive means of closing. Where that vertical distance exceeds 0.02L, a single automatic non-return valve without positive means of closing may be accepted. The means for operating the positive action valve shall be readily accessible and provided with an indicator showing whether the valve is open or closed.

(1)(b) One automatic non-return valve and one sluice valve controlled from above the freeboard deck instead of one automatic non-return valve with a positive means of closing from a position above the freeboard deck, is acceptable.

(1)(c) Where two automatic non-return valves are required, the inboard valve shall always be accessible for examination under service conditions (i.e., the inboard valve shall be above the level of the Tropical Load Line). If this is not practicable, the inboard valve need not be located above the Tropical Load Line, provided that a locally controlled sluice valve is fitted between the two automatic non-return valves.

(1)(d) Where sanitary discharges and scuppers lead overboard through the shell in way of machinery spaces, a locally operated positive closing valve at the shell, together with a non-return valve inboard, is acceptable. The controls of the valves shall be in an easily accessible position.

(1)(e) The position of the inboard end of discharges shall be related to the Summer Timber Load Line when a timber freeboard is assigned.

(1)(f) The requirements for non-return valves are applicable only to those discharges which remain open during the normal operation of a ship. For discharges which are to be kept closed at sea, a single screw down valve operated from the deck is acceptable.

(1)(g) Table 22.1 provides the acceptable arrangements of scuppers, inlets and discharges.

Discharges coming from enclosed spaces below the freeboard deck or on the freeboard deck				Discharges coming from other spaces	
General requirement Reg. 22(1) where inboard end $\leq 0.01L$ above SWL	Discharges through machinery space	Alternatives (Reg. 22(1)) where inboard end		Outboard end > 450 mm below FB deck or ≤ 600 mm above SWL Reg. 22(4)	Otherwise Reg. 22(5)
		$> 0.01L$ above SWL	$> 0.02L$ above SWL		
Superstructure or deckhouse deck					
FB deck	FB deck	FB deck	FB deck	FB deck	FB deck
SWL	SWL	SWL	SWL	SWL	SWL
Symbols: inboard end of pipes outboard end of pipes pipes terminating on the open deck		Non-return valve without positive means of closing Non-return valve with positive means of closing controlled locally valve controlled locally		remote control normal thickness substantial thickness	

(2) Scuppers led through the shell from enclosed superstructures used for the carriage of cargo shall be permitted only where the edge of the freeboard deck is not immersed when the ship heels 5° either way. In other cases the drainage shall be led inboard in accordance with the requirements of the International Convention for the Safety of Life at Sea in force.

(3) In manned machinery spaces, main and auxiliary sea inlets and discharges in connection with the operation of machinery may be controlled locally. The controls shall be readily accessible and shall be provided with indicators showing whether the valves are open or closed.

(4) Scuppers and discharge pipes originating at any level and penetrating the shell either more than 450 mm below the freeboard deck or less than 600 mm above the Summer Load Line shall be provided with a non-return valve at the shell. This valve, unless required by paragraph (1), may be omitted if the piping is of substantial thickness (see paragraph (7) below).

(5) Scuppers leading from superstructures or deckhouses not fitted with doors complying with the requirements of regulation 12 shall be led overboard.

(6) All shell fittings and the valves required by this regulation shall be of steel, bronze or other approved ductile material. Valves of ordinary cast iron or similar material are not acceptable. All pipes to which this regulation refers shall be of steel or other equivalent material to the satisfaction of the Administration.

(7) Scupper and discharge pipes:

(7)(a) For scupper and discharge pipes, where substantial thickness is not required:

(7)(a)(i) for pipes having an external diameter equal to or less than 155 mm, the thickness shall not be less than 4.5 mm;

(7)(a)(ii) for pipes having an external diameter equal to or more than 230 mm, the thickness shall not be less than 6 mm.

Intermediate sizes shall be determined by linear interpolation.

(7)(b) For scupper and discharge pipes, where substantial thickness is required:

(7)(b)(i) for pipes having an external diameter equal to or less than 80 mm, the thickness shall not be less than 7 mm;

(7)(b)(ii) for pipes having an external diameter of 180 mm, the thickness shall not be less than 10 mm;

(7)(b)(iii) for pipes having an external diameter equal to or more than 220 mm, the thickness shall not be less than 12.5 mm.

Intermediate sizes shall be determined by linear interpolation.

Regulation 22-1 Garbage chutes

- (1) Two gate valves controlled from the working deck of the chute instead of the non-return valve with a positive means of closing from a position above the freeboard deck which comply with the following requirements are acceptable:
 - (1)(a) the lower gate valve shall be controlled from a position above the freeboard deck. An interlock system between the two valves shall be arranged;
 - (1)(b) the inboard end shall be located above the waterline formed by an 8.5° heel to port or starboard at a draft corresponding to the assigned summer freeboard, but not less than 1,000 mm above the summer waterline. Where the inboard end exceeds 0.01L above the summer waterline, valve control from the freeboard deck is not required, provided the inboard gate valve is always accessible under service conditions; and
 - (1)(c) alternatively, the upper and lower gate valves may be replaced by a hinged weathertight cover at the inboard end of the chute together with a discharge flap. The cover and flap shall be arranged with an interlock so that the discharge flap cannot be operated until the hopper cover is closed.
- (2) The entire chute, including the cover, shall be constructed of material of substantial thickness.
- (3) The controls for the gate valves and/or hinged covers shall be clearly marked: "Keep closed when not in use".
- (4) Where the inboard end of the chute is below the freeboard deck of a passenger ship or the equilibrium waterlines of a cargo ship to which damage stability requirements apply, then:
 - (4)(a) the inboard end hinged cover/valve shall be watertight;
 - (4)(b) the valve shall be a screw-down non-return valve fitted in an easily accessible position above the deepest load line; and
 - (4)(c) the screw-down non-return valve shall be controlled from a position above the bulkhead deck and provided with open/closed indicators. The valve control shall be clearly marked: "Keep closed when not in use".

Regulation 22-2 Spurling pipes and cable lockers

- (1) Spurling pipes and cable lockers shall be watertight up to the deck exposed to weather.
- (2) Where means of access are provided, they shall be closed by a substantial cover and secured by closely spaced bolts.
- (3) Spurling pipes through which anchor cables are led shall be provided with permanently attached closing appliances to minimize water ingress.

Regulation 23 Side scuttles, windows and skylights

- (1) Side scuttles and windows, together with their glasses, deadlights and storm covers^{iv)}, if fitted, shall be of an approved design and substantial construction. Non-metallic frames are not acceptable.
 - (2) Side scuttles are defined as being round or oval openings with an area not exceeding 0.16 m². Round or oval openings having areas exceeding 0.16 m² shall be treated as windows.
 - (3) Windows are defined as being rectangular openings generally, having a radius at each corner relative to the window size and round or oval openings with an area exceeding 0.16 m².
 - (4) Side scuttles to the following spaces shall be fitted with hinged inside deadlights:
 - (4)(a) spaces below freeboard deck;
 - (4)(b) spaces within the first tier of enclosed superstructures; and
 - (4)(c) first tier deckhouses on the freeboard deck protecting openings leading below or considered buoyant in stability calculations.
- Deadlights shall be capable of being closed and secured watertight if fitted below the freeboard deck and weathertight if fitted above.
- (5) Side scuttles shall not be fitted in such a position that their sills are below a line drawn parallel to the freeboard deck at side and having its lowest point 2.5% of the breadth (B), or 500 mm, whichever is the greatest distance, above the Summer Load Line (or Timber Summer Load Line if assigned).
 - (6) If the required damage stability calculations indicate that the side scuttles would become immersed at any intermediate stage of flooding or the final equilibrium waterline, they shall be of the non-opening type.
 - (7) Windows shall not be fitted in the following locations:
 - (7)(a) below the freeboard deck;
 - (7)(b) in the first tier end bulkheads or sides of enclosed superstructures; or
 - (7)(c) in first tier deckhouses that are considered buoyant in the stability calculations.
 - (8) Side scuttles and windows at the side shell in the second tier shall be provided with hinged inside deadlights capable of being closed and secured weathertight if the superstructure protects direct access to an

opening leading below or is considered buoyant in the stability calculations.

(9) Side scuttles and windows in side bulkheads set inboard from the side shell in the second tier which protect direct access below to spaces listed in paragraph (4) shall be provided with either hinged inside deadlights or, where they are accessible, permanently attached external storm covers which are capable of being closed and secured weathertight.

(10) Cabin bulkheads and doors in the second tier and above separating side scuttles and windows from a direct access leading below or the second tier considered buoyant in the stability calculations may be accepted in place of deadlights or storm covers fitted to the side scuttles and windows.

(11) Deckhouses situated on a raised quarter deck or on the deck of a superstructure of less than standard height may be regarded as being in the second tier as far as the requirements for deadlights are concerned, provided that the height of the raised quarter deck or superstructure is equal to or greater than the standard quarter deck height.

(12) Fixed or opening skylights shall have a glass thickness appropriate to their size and position as required for side scuttles and windows. Skylight glasses in any position shall be protected from mechanical damage and, where fitted in position 1 or 2, shall be provided with permanently attached deadlights or storm covers.

Regulation 24 Freeing ports

(1)(a) Where bulwarks on the weather portions of freeboard or superstructure decks form wells, ample provision shall be made for rapidly freeing the decks of water and for draining them.

(1)(b) Except as provided in paragraphs (1)(c) and (2), the minimum freeing port area (A) on each side of the ship for each well on the freeboard deck shall be that given by the following formulae in cases where the sheer in way of the well is standard or greater than standard.

The minimum area for each well on superstructure decks shall be one-half of the area given by the following formulae:

Where the length of bulwark (l) in the well is 20 m or less:

$$A = 0.7 + 0.035 \times l \text{ (m}^2\text{)}$$

where l exceeds 20 m: $A = 0.07 \times l \text{ (m}^2\text{)}$.

l need in no case be taken as greater than 0.7L.

If the bulwark is more than 1.2 m in average height, the required area shall be increased by 0.004 m² per metre of length of well for each 0.1 m difference in height. If the bulwark is less than 0.9 m in average height, the required area may be decreased by 0.004 m² per m of length of well for each 0.1 m difference in height.

(1)(c) In ships with no sheer, the area calculated according to paragraph (b) shall be increased by 50%. Where the sheer is less than the standard, the percentage shall be obtained by linear interpolation.

(1)(d) On a flush deck ship with a deckhouse amidships having a breadth at least 80% of the beam of the ship and the passageways along the side of the ship not exceeding 1.5 m in width, two wells are formed. Each shall be given the required freeing port area based upon the length of each well.

(1)(e) Where a screen bulkhead is fitted completely across the ship at the forward end of a midship deckhouse, the exposed deck is divided into two wells and there is no limitation on the breadth of the deckhouse.

(1)(f) Wells on raised quarterdecks shall be treated as being on freeboard decks.

(1)(g) Gutter bars greater than 300 mm in height fitted around the weather decks of tankers in way of cargo manifolds and cargo piping shall be treated as bulwarks. Freeing ports shall be arranged in accordance with this regulation. Closures attached to the freeing ports for use during loading and discharge operations are to be arranged in such a way that jamming cannot occur while at sea.

(2) Where a ship fitted with a trunk does not comply with the requirements of regulation 36(1)(e) or where continuous or substantially continuous hatchway side coamings are fitted between detached superstructures, the minimum area of the freeing port openings shall be calculated from the following table:

Breadth of hatchway or trunk in relation to the breadth of ship	Area of freeing ports in relation to the total area of the bulwarks
40% or less	20%
75% or more	10%

The area of freeing ports at intermediate breadths shall be obtained by linear interpolation.

(3) The effectiveness of the freeing area in bulwarks required by paragraph (1) depends on the free flow area across the deck of a ship.

The free flow area on deck is the net area of gaps between hatchways, and between hatchways and superstructures and deckhouses up to the actual height of the bulwark.

The freeing port area in bulwarks shall be assessed in relation to the net free flow area as follows:

(3)(a) If the free flow area is not less than the freeing area calculated from paragraph (2) as if the hatchway coamings were continuous, then the minimum freeing port area calculated from paragraph (1) shall be deemed sufficient.

(3)(b) If the free flow area is equal to, or less than the area calculated from paragraph (1), the minimum freeing area in the bulwarks shall be determined from paragraph (2).

(3)(c) If the free flow area is smaller than calculated from paragraph (2), but greater than calculated from paragraph (1), the minimum freeing area in the bulwark shall be determined from the following formula:

$$F = F_1 + F_2 - f_p \quad (\text{m}^2)$$

where:

F_1 is the minimum freeing area calculated from paragraph (1);

F_2 is the minimum freeing area calculated from paragraph (2); and

f_p is the total net area of passages and gaps between hatch ends and superstructures or deckhouses up to the actual height of bulwark.

(4) In ships having superstructures on the freeboard deck or superstructure decks, which are open at either or both ends to wells formed by bulwarks on the open decks, adequate provision for freeing the open spaces within the superstructures shall be provided.

The minimum freeing port area on each side of the ship for the open superstructure (A_s) and for the open well (A_w), shall be calculated in accordance with the following procedure:

(4)(a) Determine the total well length (l_t) equal to the sum of the length of the open deck enclosed by bulwarks (l_w) and the length of the common space within the open superstructure (l_s).

(4)(b) To determine A_s :

(4)(b)(i) calculate the freeing port area (A) required for an open well of length l_t in accordance with paragraph (1) with standard height bulwark assumed;

(4)(b)(ii) multiply by a factor of 1.5 to correct for the absence of sheer, if applicable, in accordance with paragraph (1)(c);

(4)(b)(iii) multiply by the factor (b_o/l_t) to adjust the freeing port area for the breadth (b_o) of the openings in the end bulkhead of the enclosed superstructure;

(4)(b)(iv) to adjust the freeing port area for that part of the entire length of the well which is enclosed by the open superstructure, multiply by the factor:

$$1 - (l_w/l_t)^2$$

where l_w and l_t are defined in paragraph (4)(a);

(4)(b)(v) to adjust the freeing port area for the distance of the well deck above the freeboard deck, for decks located more than 0.5 h_s above the freeboard deck, multiply by the factor :

$$0.5 (h_s/h_w)$$

where

h_w is the distance of the well deck above the freeboard deck and h_s one standard superstructure height.

(4)(c) To determine A_w :

(4)(c)(i) the freeing port area for the open well (A_w) shall be calculated in accordance with paragraph (b)(i), using l_w to calculate a nominal freeing port area (A'), and then adjusted for the actual height of the bulwark (h_b) by the application of one of the following area corrections, whichever is applicable:

for bulwarks greater than 1.2 m in height:

$$A_c = l_w \times [(h_b - 1.2)/0.10] \times (0.004) \quad (\text{m}^2);$$

for bulwarks less than 0.9 m in height:

$$A_c = l_w \times [(h_b - 0.9)/0.10] \times (0.004) \quad (\text{m}^2);$$

for bulwarks between 1.2 m and 0.9 m in height there is no correction (i.e. $A_c = 0$);

(4)(c)(ii) the corrected freeing port area ($A_w = A' + A_c$) shall then be adjusted for absence of sheer, if applicable, and height above freeboard deck as in paragraphs (b)(ii) and (b)(v), using h_s and h_w .

(4d) The resulting freeing port areas for the open superstructure (A_s) and for the open well (A_w) shall be provided along each side of the open space covered by the open superstructure and each side of the open well, respectively.

(4e) The above relationships are summarised by the following equations, assuming l_t , the sum of l_w and l_s , is greater than 20 m:

freeing port area A_w for the open well:

$$A_w = (0.07 \times l_w + A_c) \times (\text{sheer correction}) \times (0.5h_s/h_w);$$

freeing port area A_s for the open superstructure:

$$A_s = (0.07 \times l_t) \times (\text{sheer correction}) \times (b_o/l_t) \times [1 - (l_w/l_t)^2] \times (0.5h_s/h_w);$$

where l_t is 20 m or less, the basic freeing port area is $A = 0.7 + 0.035 \times l_t$ in accordance with paragraph (1).

(5) The lower edges of freeing ports shall be as near the deck as practicable. Two-thirds of the freeing port area required shall be provided in the half of the well nearest the lowest point of the sheer curve. One third of the freeing port area required shall be evenly spread along the remaining length of the well. With zero or little sheer on the exposed freeboard deck or an exposed superstructure deck the freeing port area shall be evenly spread along the length of the well.

(6) All freeing port openings in the bulwarks shall be protected by rails or bars spaced approximately 230 mm apart. If shutters are fitted to freeing ports, ample clearance shall be provided to prevent jamming. Hinges shall have pins or bearings of non-corrodible material. Shutters shall not be fitted with securing appliances.

Regulation 25 Protection of the crew

(1) The deckhouses used for the accommodation of the crew shall be constructed to an acceptable level of strength.

(2) Guard rails or bulwarks shall be fitted around all exposed decks. The height of the bulwarks or guard rails shall be at least 1 m from the deck, provided that where this height would interfere with the normal operation of the ship, a lesser height may be approved, if the Administration is satisfied that adequate protection is provided.

(3) Guard rails fitted on superstructure and freeboard decks shall have at least three courses. The opening below the lowest course of the guard rails shall not exceed 230 mm. The other courses shall be not more than 380 mm apart. In the case of ships with rounded gunwales the guard rail supports shall be placed on the flat of the deck. In other locations, guardrails with at least two courses shall be fitted. Guard rails shall comply with the following provisions:

(3)(a) fixed, removable or hinged stanchions shall be fitted about 1.5 m apart. Removable or hinged stanchions shall be capable of being locked in the upright position;

(3)(b) at least every third stanchion shall be supported by a bracket or stay;

(3)(c) where necessary for the normal operation of the ship, steel wire ropes may be accepted in lieu of guard rails. Wires shall be made taut by means of turnbuckles; and

(3)(d) where necessary for the normal operation of the ship, chains fitted between two fixed stanchions and/or bulwarks are acceptable in lieu of guard rails.

(4) Satisfactory means for safe passage required by regulation 25-1 (in the form of guard rails, lifelines, gangways or underdeck passages, etc.) shall be provided for the protection of the crew in getting to and from their quarters, the machinery space and any other spaces used in the essential operation of the ship.

(5) Deck cargo carried on any ship shall be so stowed that any opening which is in way of the cargo and which gives access to and from the crew's quarters, the machinery space and all other parts used in the essential operation of the ship can be closed and secured against water ingress. Protection for the crew in the form of guard rails or lifelines shall be provided above the deck cargo if there is no convenient passage on or below the deck of the ship.

Regulation 25-1 Means for safe passage of crew

(1) The safe passage of crew shall be provided by at least one of the means prescribed in table 25-1.1 below:

Type of ship	Locations of access in Ship	Assigned Summer Freeboard	Acceptable arrangements according to type of freeboard assigned***			
			Type "A"	Type "B-100"	Type "B-60"	Type "B" and "B+"
All ships other than oil tankers*, chemical tankers* and gas carriers*	<i>1.1. Access to Mid- ship Quarters</i>	≤ 3 000 mm	(a) (b) (c)	(a) (b) (c)	(a) (b) (c) (i) (e) (f)	(a) (b) (c) (i) (c) (ii) (c) (iv)
	1.1.1. Between poop and bridge, or 1.1.2. Between poop and deckhouse containing living accommodation navigating equipment or both	> 3 000 mm	(a) (b) (c)	(a) (b) (c)	(a) (b) (c) (i) (c) (ii) (e) (f) (i)	(d) (i) (d) (ii) (d) (iii) (e) (f) (i) (f) (ii)

					(f) (ii)	(f) (iv)
	1.2 Access to Ends					
	1.2.1. Between poop and bow (if there is no bridge),	≤ 3 000 mm	(a) (b) (c) (i) (e) (f) (i)	(a) (b) (c) (i) (c) (ii) (e) (f) (i) (f) (ii)	(a) (b) (c) (i) (c) (ii) (e) (f) (i) (f) (ii)	
	1.2.2. Between bridge and bow, or	> 3 000 mm	(a) (b) (c) (i) (d) (i) (e) (f) (i)	(a) (b) (c) (i) (c) (ii) (d) (i) (d) (ii) (e) (f) (i) (f) (ii)	(a) (b) (c) (i) (c) (ii) (c) (iv) (d) (i) (d) (ii) (d) (iii) (e) (f) (i) (f) (ii) (f) (iv)	
	1.2.3. Between a deckhouse containing living accommodation or navigating equipment, or both, and bow, or					
1.2.4. In the case of a flush deck vessel, between crew accommodation and the forward and after ends of the ship.						
Oil tankers*, chemical tankers* and gas carriers*	2.1 Access to bow				(a)	
	2.1.1 Between poop and bow or	≤ (A _r + H _s)**			(e) (f) (i) (f) (v)	
	2.1.2 Between deckhouse containing living accommodation or navigating equipment, or both, and bow, or	> (A _r + H _s)**			(a) (e) (f) (i) (f) (ii)	
	2.1.3 In the case of flush deck ship, between crew accommodation and forward ends of ship					
	2.2 Access to after end					
	In the case of flush deck ship between crew accommodation and the after end of ship					As required in 1.2.4 for other types of ships

* Oil tankers, chemical tankers and gas carriers as defined in regulations II-1/2.12, VII/8.2 and VII/1.2, respectively, of the International Convention for the Safety of Life at Sea, 1974, as amended.

** A_r: the minimum summer freeboard calculated as type 'A' ship regardless of the type freeboard actually assigned. H_s: the standard height of superstructure as defined in regulation 33.

*** Arrangements (a)-(f) are described in paragraph (2) below. Locations (i)-(v) are described in paragraph (3) below.

(2) Acceptable arrangements referred to in table 25-1.1 are defined as follows:

(2)(a) A well lighted and ventilated under-deck passageway (with a clear opening of at least 0.8 m wide and 2 m high), as close as practicable to the freeboard deck, connecting and providing access to the locations in question.

(2)(b) A permanent and efficiently constructed gangway, fitted at or above the level of the superstructure deck, on or as near as practicable to the centre line of the ship, providing a continuous platform at least 0.6 m in width and a non-slip surface and with guard rails extending on each side throughout its length. Guard rails shall be at least 1 m high with three courses and constructed as required in regulation 25(3). A foot-stop shall be provided.

(2)(c) A permanent walkway at least 0.6 m in width, fitted at freeboard deck level and consisting of two rows of guard rails with stanchions spaced not more than 3 m. The number of courses of rails and their spacing shall be in accordance with regulation 25(3). On type 'B' ships, hatchway coamings not less than 0.6 m in height may be accepted as forming one side of the walkway, provided that two rows of guard rails are fitted between the hatchways.

(2)(d) A wire rope lifeline not less than 10 mm in diameter, supported by stanchions not more than 10 m apart, or a single hand rail or wire rope attached to hatch coamings, continued and supported between hatchways.

(2)(e) A permanent gangway that is:

(2)(e)(i) located at or above the level of the superstructure deck;

(2)(e)(ii) located on or as near as practicable to the centre line of the ship;

(2)(e)(iii) located so as not to hinder easy access across the working areas of the deck;

(2)(e)(iv) providing a continuous platform at least 1 m in width;

(2)(e)(v) constructed of fire resistant and non-slip material;

- (2)(e)(vi) fitted with guard rails extending on each side throughout its length; guard rails shall be at least 1 m high with courses as required by regulation 25(3) and supported by stanchions spaced not more than 1.5 m apart;
- (2)(e)(vii) provided with a foot-stop on each side;
- (2)(e)(viii) having openings, with ladders where appropriate, to and from the deck. Openings shall not be more than 40 m apart; and
- (2)(e)(ix) having shelters set in way of the gangway at intervals not exceeding 45 m if the length of the exposed deck to be traversed exceeds 70 m. Every such shelter shall be capable of accommodating at least one person and be so constructed as to afford weather protection on the forward, port and starboard sides.
- (2)(f) A permanent walkway located at the freeboard deck level, on or as near as practicable to the centre line of the ship, having the same specifications as those for a permanent gangway listed in (e), except for foot-stops. On type 'B' ships (certified for the carriage of liquids in bulk) with a combined height of hatch coaming and fitted hatch cover of not less than 1 m in height, the hatchway coamings may be accepted as forming one side of the walkway, provided that two rows of guard rails are fitted between the hatchways.
- (3) Permitted transverse locations for arrangements in paragraphs (2)(c), (d) and (f) above, where appropriate:
 - (3)(i) at or near the centre line of the ship; or fitted on hatchways at or near the centre line of the ship;
 - (3)(ii) fitted on each side of the ship;
 - (3)(iii) fitted on one side of the ship, provision being made for fitting on either side;
 - (3)(iv) fitted on one side of the ship only;
 - (3)(v) fitted on each side of the hatchways, as near to the centre line as practicable.
- (4)(a) Where wire ropes are fitted, turnbuckles shall be provided to ensure their tautness.
- (4)(b) Where necessary for the normal operation of the ship, steel wire ropes may be accepted in lieu of guard rails.
- (4)(c) Where necessary for the normal operation of the ship, chains fitted between two fixed stanchions are acceptable in lieu of guard rails.
- (4)(d) Where stanchions are fitted, every third stanchion shall be supported by a bracket or stay.
- (4)(e) Removable or hinged stanchions shall be capable of being locked in the upright position.
- (4)(f) A means of passage over obstructions such as pipes or other fittings of a permanent nature, shall be provided.
- (4)(g) Generally, the width of the gangway or deck-level walkway should not exceed 1.5 m.
- (5) For tankers less than 100 m in length, the minimum width of the gangway platform or deck-level walkway fitted in accordance with paragraphs (2)(e) or (f) above, respectively, may be reduced to 0.6 m.

Regulation 26 Special conditions of assignment for type "A" ships

Machinery casings

- (1) Machinery casings on type 'A' ships, as defined in regulation 27, shall be protected by one of the following arrangements:
 - (1)(a) an enclosed poop or bridge of at least standard height; or
 - (1)(b) a deckhouse of equal height and equivalent strength.
- (2) Machinery casings may, however, be exposed if there are no openings giving direct access from the freeboard deck to the machinery space. A door complying with the requirements of regulation 12 is acceptable in the machinery casing, provided that it leads to a space or passageway which is as strongly constructed as the casing and is separated from the stairway to the engine-room by a second weathertight door of steel or other equivalent material.

Gangway and access

- (3) A fore and aft permanent gangway, constructed in accordance with the provisions of regulation 25-1(2)(e), shall be fitted on type 'A' ships at the level of the superstructure deck between the poop and the midship bridge or deckhouse where fitted. The arrangement contained in regulation 25-1(2)(a) is considered an equivalent means of access to carry out the purpose of the gangway.
- (4) Safe access from the gangway level shall be available between separate crew accommodations and also between crew accommodations and the machinery space.

Hatchways

- (5) Exposed hatchways on the freeboard and forecastle decks or on the tops of expansion trunks on type 'A' ships shall be provided with efficient watertight covers of steel or other equivalent material.

Freeing arrangements

- (6) Type 'A' ships with bulwarks shall have open rails fitted for at least half the length of the weather deck or

other equivalent freeing arrangements. A freeing port area, in the lower part of the bulwarks, of 33% of the total area of the bulwarks, is an acceptable equivalent freeing arrangement. The upper edge of the sheer strake shall be kept as low as practicable.

(7) Where superstructures are connected by trunks, open rails shall be fitted for the whole length of the exposed parts of the freeboard deck.

Annex 1
Regulations for determining load lines
Chapter III
Freeboards

Regulation 27 Types of ships

(1) For the purposes of freeboard computation, ships shall be divided into type 'A' and type 'B'.

Type 'A' ships

(2) A type 'A' ship is one which:

(2)(a) is designed to carry only liquid cargoes in bulk;

(2)(b) has a high integrity of the exposed deck with only small access openings to cargo compartments, closed by watertight gasketed covers of steel or equivalent material; and

(2)(c) has low permeability of loaded cargo compartments.

(3) A type 'A' ship, if over 150 m in length, to which a freeboard less than type 'B' has been assigned, when loaded in accordance with the requirements of paragraph (11), shall be able to withstand the flooding of any compartment or compartments, with an assumed permeability of 0.95, consequent upon the damage assumptions specified in paragraph (12), and shall remain afloat in a satisfactory condition of equilibrium, as specified in paragraph (13). In such a ship, the machinery space shall be treated as a floodable compartment, but with a permeability of 0.85.

(4) A type 'A' ship shall be assigned a freeboard not less than that based on table 28.1.

Type 'B' ships

(5) All ships which do not come within the provisions regarding type 'A' ships in paragraphs (2) and (3) shall be considered as type 'B' ships.

(6) Type 'B' ships, which in position 1 have hatch covers which are permitted by the Administration to comply with the requirements of regulation 15 (other than paragraph (6) or which are fitted with securing arrangements accepted under the provisions of regulation 16(6), shall be assigned freeboards based upon the values given in table 28.2, increased by the values given in table 27.1:

Table 27.1 - Freeboard increase over tabular freeboard for type 'B' ships, for ships with hatch covers complying with the provisions of regulation 15 (other than paragraph (6))

<i>Length Of Ship (m)</i>	<i>Freeboard increase (mm)</i>	<i>Length of ship (m)</i>	<i>Freeboard increase (mm)</i>	<i>Length of ship (m)</i>	<i>Freeboard increase (mm)</i>
≤108	50	139	175	170	290
109	52	140	181	171	292
110	55	141	186	172	294
111	57	142	191	173	297
112	59	143	196	174	299
113	62	144	201	175	301
114	64	145	206	176	304
115	68	146	210	177	306
116	70	147	215	178	308
117	73	148	219	179	311
118	76	149	224	180	313

119	80	150	228	181	315
120	84	151	232	182	318
121	87	152	236	183	320
122	91	153	240	184	322
123	95	154	244	185	325
124	99	155	247	186	327
125	103	156	251	187	329
126	108	157	254	188	332
127	112	158	258	189	334
128	116	159	261	190	336
129	121	160	264	191	339
130	126	161	267	192	341
131	131	162	270	193	343
132	136	163	273	194	346
133	142	164	275	195	348
134	147	165	278	196	350
135	153	166	280	197	353
136	159	167	283	198	355
137	164	168	285	199	357
138	170	169	287	200	358
Freeboards at intermediate lengths of ship shall be obtained by linear interpolation. Ships above 200 m in length shall be dealt with by the Administration.					

(7) Type 'B' ships, which in position 1 have hatchways fitted with hatch covers complying with the requirements of regulation 16(2) through (5), shall, except as provided in paragraphs (8) to (13) inclusive, be assigned freeboards based on table 28.2.

(8) Any type 'B' ship of over 100 m in length may be assigned freeboards less than those required under paragraph (7), provided that, in relation to the amount of reduction granted, the Administration is satisfied that:

(8)(a) the measures provided for the protection of the crew are adequate;

(8)(b) the freeing arrangements are adequate;

(8)(c) the covers in position 1 and 2 comply with the provisions of regulation 16(1) through (5) and (7); and

(8)(d) the ship, when loaded in accordance with the requirements of paragraph (11), shall be able to withstand the flooding of any compartment or compartments, with an assumed permeability of 0.95, consequent upon the damage assumptions specified in paragraph (12), and shall remain afloat in a satisfactory condition of equilibrium, as specified in paragraph (13). In such a ship, if over 150 m in length, the machinery space shall be treated as a floodable compartment, but with a permeability of 0.85.

(9) In calculating the freeboards for type 'B' ships which comply with the requirements of paragraphs (8), (11), (12) and (13), the values from table 28.2 shall not be reduced by more than 60% of the difference between the tabular values in tables 28.1 and 28.2.

(10) (a) The reduction in tabular freeboard allowed under paragraph (9) may be increased up to the total difference between the values in table 28.1 and those in table 28.2 on condition that the ship complies with the requirements of:

(10)(a)(i) regulation 26, other than paragraph (5), as if it were a type 'A' ship;

(10)(a)(ii) paragraphs (8), (11) and (13); and

(10)(a)(iii) paragraph (12), provided that throughout the length of the ship any one transverse bulkhead will be assumed to be damaged, such that two adjacent fore and aft compartments shall be flooded simultaneously,

except that such damage will not apply to the boundary bulkheads of a machinery space.

(10)(b) In such a ship, if over 150 m in length, the machinery space shall be treated as a floodable compartment, but with a permeability of 0.85.

Initial condition of loading

(11) The initial condition of loading before flooding shall be determined as follows:

(11)(a) The ship is loaded to its summer load waterline on an imaginary even keel.

(11)(b) When calculating the vertical centre of gravity, the following principles apply:

(11)(b)(i) homogeneous cargo is carried;

(11)(b)(ii) all cargo compartments, except those referred to under subparagraph (iii), but including compartments intended to be partially filled, shall be considered fully loaded except that in the case of fluid cargoes each compartment shall be treated as 98% full;

(11)(b)(iii) if the ship is intended to operate at its summer load waterline with empty compartments, such compartments shall be considered empty, provided the height of the centre of gravity so calculated is not less than as calculated under subparagraph (ii);

(11)(b)(iv) 50 per cent of the ship's total capacity of tanks and spaces fitted to contain each type of consumables and stores is allowed for. It shall be assumed that for each type of liquid at least one transverse pair or a single centreline tank has maximum free surface, and the tank or combination of tanks to be taken into account shall be those where the effect of free surfaces is the greatest; in each tank the centre of gravity of the contents shall be taken at the centre of volume of the tank. The remaining tanks shall be assumed either completely empty or completely filled, and the distribution of consumable liquids between these tanks shall be effected so as to obtain the greatest possible height above the keel for the centre of gravity.

(11)(b)(v) At an angle of heel of not more than 5° in each compartment containing liquids as prescribed in (ii) except in the case of the compartments containing consumable liquids as provided in (iv) account shall be taken of the effect of the maximum free surfaces. Alternatively, the effects of the actual free surface can be used, if the Administration can approve the calculation methods.

(11)(b)(vi) Weights shall be calculated on the basis of the following values for specific gravities: salt water 1.025

Fresh water 1.000

Oil fuel 0.950

Diesel oil 0.900

Lubricating oil 0.900.

Damage assumptions

(12) The following principles regarding the character of the assumed damage apply:

(12)(a) The vertical extent of damage in all cases is assumed to be from the base line upwards without limit.

(12)(b) The transverse extent of damage is equal to B/5 or 11.5 m, whichever is the lesser, measured inboard from the side of the ship perpendicularly to the centreline at the level of the summer load waterline.

(12)(c) If damage of a lesser extent than specified in subparagraphs (a) and (b) results in a more severe condition, such lesser extent shall be assumed.

(12)(d) Except where otherwise required by paragraph (10)(a), the flooding shall be confined to a single compartment between adjacent transverse bulkheads, provided that the inner longitudinal boundary of the compartment is not in a position within the transverse extent of assumed damage. Transverse boundary bulkheads of wing tanks, which do not extend over the full breadth of the ship shall be assumed not to be damaged, provided that they extend beyond the transverse extent of assumed damage prescribed in subparagraph (b).

If in a transverse bulkhead there are steps or recesses of not more than 3 m in length, located within the transverse extent of assumed damage as defined in subparagraph (b), such transverse bulkhead may be considered intact and the adjacent compartment may be floodable singly. If, however, within the transverse extent of assumed damage there is a step or recess of more than 3 m in length in a transverse bulkhead, the two compartments adjacent to this bulkhead shall be considered as flooded. The step formed by the afterpeak bulkhead and the afterpeak tank top shall not be regarded as a step for the purpose of this regulation.

(12)(e) Where a main transverse bulkhead is located within the transverse extent of assumed damage and is stepped in way of a double bottom or side tank by more than 3 m, the double bottom or side tanks adjacent to the stepped portion of the main transverse bulkhead shall be considered as flooded simultaneously. If this side tank has openings into one or several holds, such hold or holds shall be considered

as flooded simultaneously. Similarly, in a ship designed for the carriage of fluid cargoes, if a side tank has openings into adjacent compartments, such adjacent compartments shall be considered as empty and as being flooded simultaneously. This provision is applicable even where such openings are fitted with closing appliances, except in the case of sluice valves fitted in bulkheads between tanks and where the valves are controlled from the deck. Manhole covers with closely spaced bolts are considered equivalent to the unpierced bulkhead, except in the case of openings in topside tanks making the topside tanks common to the holds.

(12)(f) Where the flooding of any two adjacent fore and aft compartments is envisaged, main transverse watertight bulkheads shall be spaced at least $1/3L$ $2/3$ or 14.5 m, whichever is the lesser, in order to be considered effective. Where transverse bulkheads are spaced at a lesser distance, one or more of these bulkheads shall be assumed as non-existent in order to achieve the minimum spacing between bulkheads.

Condition of equilibrium

(13) The condition of equilibrium after flooding shall be regarded as satisfactory provided:

(13)(a) The final waterline after flooding, taking into account sinkage, heel and trim, is below the lower edge of any opening through which progressive downflooding may take place. Such openings shall include air pipes, ventilators (even if they comply with regulation 19(4)) and openings which are closed by means of weathertight doors (even if they comply with regulation 12) or hatch covers (even if they comply with regulation 16(1) through (5)), and may exclude those openings closed by means of manhole covers and flush scuttles (which comply with regulation 18), cargo hatch covers of the type described in regulation 27(2), remotely operated sliding watertight doors, and sidescuttles of the non-opening type (which comply with regulation 23). However, in the case of doors separating a main machinery space from a steering gear compartment, watertight doors may be of a hinged, quick-acting type kept closed at sea whilst not in use, provided also that the lower sill of such doors is above the summer load waterline.

(13)(b) If pipes, ducts or tunnels are situated within the assumed extent of damage penetration as defined in paragraph (12)(b), arrangements shall be made so that progressive flooding cannot thereby extend to compartments other than those assumed to be floodable in the calculation for each case of damage.

(13)(c) The angle of heel due to unsymmetrical flooding does not exceed 15°. If no part of the deck is immersed, an angle of heel of up to 17° may be accepted.

(13)(d) The metacentric height in the flooded condition is positive.

(13)(e) When any part of the deck outside the compartment assumed flooded in a particular case of damage is immersed, or in any case where the margin of stability in the flooded condition may be considered doubtful, the residual stability is to be investigated. It may be regarded as sufficient if the righting lever curve has a minimum range of 20° beyond the position of equilibrium with a maximum righting lever of at least 0.1 m within this range. The area under the righting lever curve within this range shall be not less than 0.0175 m·rad. The Administration shall give consideration to the potential hazard presented by protected or unprotected openings which may become temporarily immersed within the range of residual stability.

(13)(f) The Administration is satisfied that the stability is sufficient during intermediate stages of flooding.

Ships without means of propulsion

(14) A lighter, barge or other ship without independent means of propulsion shall be assigned a freeboard in accordance with the provisions of these regulations. Barges which meet the requirements of paragraphs (2) and (3) may be assigned type 'A' freeboards:

(14)(a) The Administration should especially consider the stability of barges with cargo on the weather deck.

Deck cargo can only be carried on barges to which the ordinary type 'B' freeboard is assigned.

(14)(b) However, in the case of barges which are unmanned, the requirements of regulations 25,26(3),26(4) and 39 shall not apply

(14)(c) Such unmanned barges which have on the freeboard deck only small access openings closed by watertight gasketed covers of steel or equivalent material may be assigned a freeboard 25% less than those calculated in accordance with these regulations.

Regulation 28 Freeboard tables -Type A ships

(1) The tabular freeboard for type 'A' ships shall be determined from table 28.1:

Table 28.1

Freeboard table for type 'A' ships

Length of Ship	Freeboard increase (mm)	Length of Ship	Freeboard increase (mm)	Length of ship (m)	Freeboard increase (mm)
-----------------------	--------------------------------	-----------------------	--------------------------------	---------------------------	--------------------------------

(m)		(m)			
24	200	51	455	78	814
25	208	52	467	79	828
26	217	53	478	80	841
27	225	54	490	81	855
28	233	55	503	82	869
29	242	56	516	83	883
30	250	57	530	84	897
31	258	58	544	85	911
32	267	59	559	86	926
33	275	60	573	87	940
34	283	61	587	88	955
35	292	62	600	89	969
36	300	63	613	90	984
37	308	64	626	91	999
38	316	65	639	92	1014
39	325	66	653	93	1029
40	334	67	666	94	1044
41	344	68	680	95	1059
42	354	69	693	96	1074
43	364	70	706	97	1089
44	374	71	720	98	1105
45	385	72	733	99	1120
46	396	73	746	100	1135
47	408	74	760	101	1151
48	420	75	773	102	1166
49	432	76	786	103	1181
50	443	77	800	104	1196
105	1212	168	2240	231	2880
106	1228	169	2254	232	2888
107	1244	170	2268	233	2895
108	1260	171	2281	234	2903
109	1276	172	2294	235	2910
110	1293	173	2307	236	2918
111	1309	174	2320	237	2925
112	1326	175	2332	238	2932
113	1342	176	2345	239	2939
114	1359	177	2357	240	2946
115	1376	178	2369	241	2953
116	1392	179	2381	242	2959
117	1409	180	2393	243	2966
118	1426	181	2405	244	2973
119	1442	182	2416	245	2979
120	1459	183	2428	246	2986
121	1476	184	2440	247	2993
122	1494	185	2451	248	3000
123	1511	186	2463	249	3006
124	1528	187	2474	250	3012
125	1546	188	2486	251	3018
126	1563	189	2497	252	3024
127	1580	190	2508	253	3030
128	1598	191	2519	254	3036
129	1615	192	2530	255	3042

130	1632	193	2541	256	3048
131	1650	194	2552	257	3054
132	1667	195	2562	258	3060
133	1684	196	2572	259	3066
134	1702	197	2582	260	3072
135	1719	198	2592	261	3078
136	1736	199	2602	262	3084
137	1753	200	2612	263	3089
138	1770	201	2622	264	3095
139	1787	202	2632	265	3101
140	1803	203	2641	266	3106
141	1820	204	2650	267	3112
142	1837	205	2659	268	3117
143	1853	206	2669	269	3123
144	1870	207	2678	270	3128
145	1886	208	2687	271	3133
146	1903	209	2696	272	3138
147	1919	210	2705	273	3143
148	1935	211	2714	274	3148
149	1952	212	2723	275	3153
150	1968	213	2732	276	3158
151	1984	214	2741	277	3163
152	2000	215	2749	278	3167
153	2016	216	2758	279	3172
154	2032	217	2767	280	3176
155	2048	218	2775	281	3181
156	2064	219	2784	282	3185
157	2080	220	2792	283	3189
158	2096	221	2801	284	3194
159	2111	222	2809	285	3198
160	2126	223	2817	286	3202
161	2141	224	2825	287	3207
162	2155	225	2833	288	3211
163	2169	226	2841	289	3215
164	2184	227	2849	290	3220
165	2198	228	2857	291	3224
166	2212	229	2865	292	3228
167	2226	230	2872	293	3233
294	3237	318	3325	342	3387
295	3241	319	3328	343	3389
296	3246	320	3331	344	3392
297	3250	321	3334	345	3394
298	3254	322	3337	346	3396
299	3258	323	3339	347	3399
300	3262	324	3342	348	3401
301	3266	325	3345	349	3403
302	3270	326	3347	350	3406
303	3274	327	3350	351	3408
304	3278	328	3353	352	3410
305	3281	329	3355	353	3412
306	3285	330	3358	354	3414
307	3288	331	3361	355	3416
308	3292	332	3363	356	3418

309	3295	333	3366	357	3420
310	3298	334	3368	358	3422
311	3302	335	3371	359	3423
312	3305	336	3373	360	3425
313	3308	337	3375	361	3427
314	3312	338	3378	362	3428
315	3315	339	3380	363	3430
316	3318	340	3382	364	3432
317	3322	341	3385	365	3433

Freeboards at intermediate lengths of ship shall be obtained by linear interpolation. Ships above 365 m in length shall be dealt with by the Administration.

Type 'B' ships

(2) The tabular freeboard for type 'B' ships shall be determined from table 28.2:

Table 28.2
Freeboard table for type 'B' ships

Length of Ship (m)	Freeboard increase (mm)	Length of Ship (m)	Freeboard increase (mm)	Length of ship (m)	Freeboard increase (mm)
24	200	70	721	116	1609
25	208	71	738	117	1630
26	217	72	754	118	1651
27	225	73	769	119	1671
28	233	74	784	120	1690
29	242	75	800	121	1709
30	250	76	816	122	1729
31	258	77	833	123	1750
32	267	78	850	124	1771
33	275	79	868	125	1793
34	283	80	887	126	1815
35	292	81	905	127	1837
36	300	82	923	128	1859
37	308	83	942	129	1880
38	316	84	960	130	1901
39	325	85	978	131	1921
40	334	86	996	132	1940
41	344	87	1015	133	1959
42	354	88	1034	134	1979
43	364	89	1054	135	2000
44	374	90	1075	136	2021
45	385	91	1096	137	2043
46	396	92	1116	138	2065
47	408	93	1135	139	2087
48	420	94	1154	140	2109
49	432	95	1172	141	2130
50	443	96	1190	142	2151
51	455	97	1209	143	2171
52	467	98	1229	144	2190
53	478	99	1250	145	2209
54	490	100	1271	146	2229

55	503	101	1293	147	2250
56	516	102	1315	148	2271
57	530	103	1337	149	2293
58	544	104	1359	150	2315
59	559	105	1380	151	2334
60	573	106	1401	152	2354
61	587	107	1421	153	2375
62	601	108	1440	154	2396
63	615	109	1459	155	2418
64	629	110	1479	156	2440
65	644	111	1500	157	2460
66	659	112	1521	158	2480
67	674	113	1543	159	2500
68	689	114	1565	160	2520
69	705	115	1587	161	2540
162	2560	225	3660	288	4490
163	2580	226	3675	289	4502
164	2600	227	3690	290	4513
165	2620	228	3705	291	4525
166	2640	229	3720	292	4537
167	2660	230	3735	293	4548
168	2680	231	3750	294	4560
169	2698	232	3765	295	4572
170	2716	233	3780	296	4583
171	2735	234	3795	297	4595
172	2754	235	3808	298	4607
173	2774	236	3821	299	4618
174	2795	237	3835	300	4630
175	2815	238	3849	301	4642
176	2835	239	3864	302	4654
177	2855	240	3880	303	4665
178	2875	241	3893	304	4676
179	2895	242	3906	305	4686
180	2915	243	3920	306	4695
181	2933	244	3934	307	4704
182	2952	245	3949	308	4714
183	2970	246	3965	309	4725
184	2988	247	3978	310	4736
185	3007	248	3992	311	4748
186	3025	249	4005	312	4757
187	3044	250	4018	313	4768
188	3062	251	4032	314	4779
189	3080	252	4045	315	4790
190	3098	253	4058	316	4801
191	3116	254	4072	317	4812
192	3134	255	4085	318	4823
193	3151	256	4098	319	4834
194	3167	257	4112	320	4844
195	3185	258	4125	321	4855
196	3202	259	4139	322	4866
197	3219	260	4152	323	4878
198	3235	261	4165	324	4890
199	3249	262	4177	325	4899

200	3264	263	4189	326	4909
201	3280	264	4201	327	4920
202	3296	265	4214	328	4931
203	3313	266	4227	329	4943
204	3330	267	4240	330	4955
205	3347	268	4252	331	4965
206	3363	269	4264	332	4975
207	3380	270	4276	333	4985
208	3397	271	4289	334	4995
209	3413	272	4302	335	5005
210	3430	273	4315	336	5015
211	3445	274	4327	337	5025
212	3460	275	4339	338	5035
213	3475	276	4350	339	5045
214	3490	277	4362	340	5055
215	3505	278	4373	341	5065
216	3520	279	4385	342	5075
217	3537	280	4397	343	5086
218	3554	281	4408	344	5097
219	3570	282	4420	345	5108
220	3586	283	4432	346	5119
221	3601	284	4443	347	5130
222	3615	285	4455	348	5140
223	3630	286	4467	349	5150
224	3645	287	4478	350	5160
351	5170	356	5220	361	5268
352	5180	357	5230	362	5276
353	5190	358	5240	363	5285
354	5200	359	5250	364	5294
355	5210	360	5260	365	5303
Freeboards at intermediate lengths of ship shall be obtained by linear interpolation. Ships above 365 m in length shall be dealt with by the Administration.					

Regulation 29 Correction to the freeboard for ships under 100 m in length

The tabular freeboard for a type 'B' ship of between 24 m and 100 m in length having enclosed superstructures with an effective length of up to 35% of the length of the ship shall be increased by:

$$7.5 \cdot (100 - L) \cdot (0.35 - E_1/L) \text{ (mm)}$$

where

L is the length of the ship in m; and

E₁ is the effective length of superstructure in m as defined in regulation 35, but excluding the length of trunks.

Regulation 30 Correction for block coefficient

Where the block coefficient (C_b) exceeds 0.68, the tabular freeboard specified in regulation 28 as modified, if applicable, by regulations 27(8), 27(10) and 29 shall be multiplied by the factor:

$$(C_b + 0.68)/1.36$$

The block coefficient is not to be taken greater than 1.0.

Regulation 31 Correction for depth

(1) Where D exceeds

$$L/15$$

the freeboard shall be increased by:
 $(D - L/15) R$ mm, where R is L/0.48 at lengths
less than 120 m and 250 at 120 m length and above.

(2) Where D is less than
L/15

no reduction shall be made,

except in a ship with an enclosed superstructure covering at least 0.6L amidships, with a complete trunk, or combination of detached enclosed superstructures and trunks which extend all fore and aft, where the freeboard shall be reduced at the rate prescribed in paragraph (1).

(3) Where the height of the superstructure or trunk is less than the corresponding standard height, the calculated reduction shall be corrected in the ratio of the height of the actual superstructure or trunk to the applicable standard height, as defined in regulation 33.

Regulation 32 Correction for position of deck line

Where the actual depth to the upper edge of the deck line is greater or less than D, the difference between the depths shall be added to or deducted from the freeboard.

Regulation 32-1 Correction for recess in freeboard deck

(1) Where a recess is arranged in the freeboard deck, and it does not extend to the sides of the ship, the freeboard calculated without regard to the recess shall be corrected for the consequent loss of buoyancy. The correction shall be equal to the value obtained by dividing the volume of the recess by the waterplane area of the ship at 85% of the least moulded depth (see figure 32-1.1).

(2) The correction shall be an addition to the freeboard obtained after all other corrections have been applied, except bow height correction.

(3) Where the freeboard, corrected for lost buoyancy as above, is greater than the minimum geometric freeboard determined on the basis of a moulded depth measured to the bottom of the recess, the latter value may be used.

Figure 32-1.1

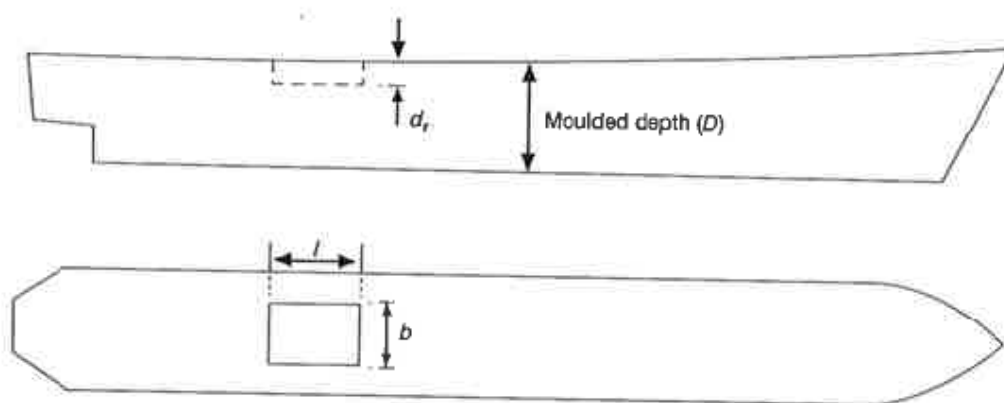

Correction is the addition to freeboard equal to:

$$\frac{l \times b \times d_r}{WP \text{ Area at } 0.85D}$$

Regulation 33 Standard height of superstructure

The standard height of a superstructure shall be as given in the following table:

Table 33.1

Standard height (in m)		
<i>L (m)</i>	<i>Raised quarterdeck</i>	<i>All other superstructures</i>
30 or less	0.9	1.8
75	1.2	1.8
125 or more	1.8	2.3

Regulation 34 Length of superstructure

(1) Except as provided in paragraph (2), the length of a superstructure (S) shall be the mean length of the parts of the superstructure which lie within the length (L).

Where a superstructure bulkhead is recessed, the effective length of the superstructure shall be reduced by an amount equal to the area of the recess in plan view divided by the breadth of the superstructure at the midlength of the recess. Where the recess is unsymmetrical about the centreline, the largest portion of the recess shall be considered as applying to both sides of the ship. A recess need not be decked over.

(2) Where the end bulkhead of an enclosed superstructure extends in a fair convex curve beyond its intersection with the superstructure sides, the length of the superstructure may be increased on the basis of an equivalent plane bulkhead. This increase shall be two-thirds of the fore and aft extent of the curvature. The maximum curvature which may be taken into account in determining this increase is one-half the breadth of the superstructure at the point of intersection of the curved end of the superstructure with its side.

Where there is an extension to a superstructure, which extension has a breadth on each side of the centre line at least 30% of the breadth of the ship, the effective length of the superstructure may be increased by considering an equivalent superstructure bulkhead in the form of a parabola. This parabola shall extend from the extension at the centreline and pass through the junction of the actual superstructure bulkhead with the sides of the extension and extend to the sides of the ship. This parabola shall be completely contained within the boundary of the superstructure and its extensions.

If the superstructure is set-in from the side, up to the limit allowed under regulation 3(10), the equivalent bulkhead should be calculated on the basis of the actual breadth of the superstructure (and not the breadth of the ship).

(3) Superstructures which have sloped end bulkheads shall be dealt with in the following manner:

(3)(a) When the height of superstructure, clear of the slope, is equal to or smaller than the standard height, length S is to be obtained as shown in figure 34.1.

(3)(b) When the height is greater than the standard, length S is to be obtained as shown in figure 34.2.

(3)(c) The foregoing will apply only when the slope, related to the base line, is 15° or greater. Where the slope is less than 15°, the configuration shall be treated as sheer.

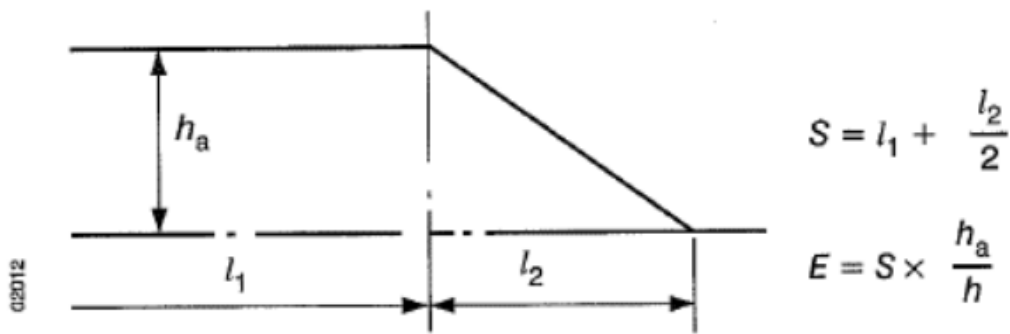

Figure 34.1

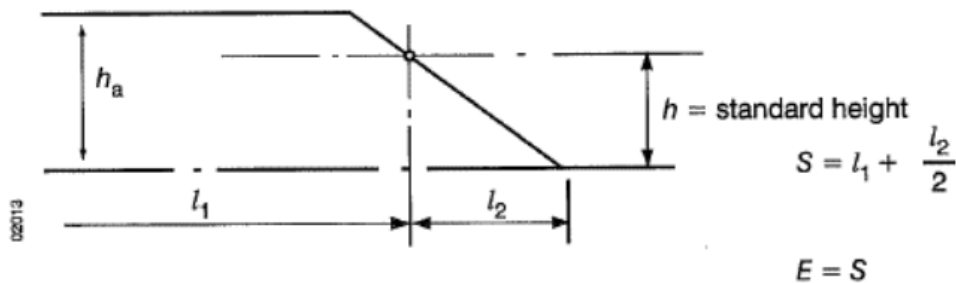

Figure 34.2

Regulation 35 Effective length of superstructure

- (1) Except as provided for in paragraph (2), the effective length (E) of an enclosed superstructure of standard height shall be its length.
 - (2) In all cases where an enclosed superstructure of standard height is set-in from the sides of the ship as permitted in regulation 3(10), the effective length shall be the length modified by the ratio of b/B_s , where: b is the breadth of the superstructure at the middle of its length; and B_s is the breadth of the ship at the middle of the length of the superstructure.
- Where a superstructure is set-in for a part of its length, this modification shall be applied only to the set-in part.
- (3) Where the height of an enclosed superstructure is less than the standard height, the effective length shall be its length reduced in the ratio of the actual height to the standard height. Where the height exceeds the standard, no increase shall be made to the effective length of the superstructure (see figures 34.1 and 34.2).
- Where the height, clear of the slope, of a superstructure which has sloped end bulkheads is less than the standard height, its effective length E shall be its length S as obtained from figure 34.1, reduced in the ratio of the actual height to the standard height.

Where a poop or forecastle of less than standard height is fitted on a ship with excessive sheer but without any superstructure within 0.2 L amidships, credit may be given to the height of the poop or forecastle by increasing the actual height by the difference between the actual and the standard sheer profiles. The deduction for excess sheer in accordance with regulation 38(16) is not to be granted.

- (4) The effective length of a raised quarter deck, if fitted with an intact front bulkhead, shall be its length up to a maximum of 0.6 L. Where the bulkhead is not intact, the raised quarter deck shall be treated as a poop of less than standard height.

The maximum effective length of 0.6 L of a raised quarterdeck is to be measured from the after perpendicular, even where a poop is fitted in conjunction with the raised quarterdeck.

- (5) Superstructures which are not enclosed shall have no effective length.

Regulation 36 Trunks

- (1) A trunk or similar structure which does not extend to the sides of the ship shall be regarded as efficient on the following conditions:
 - (1)(a) the trunk is at least as strong as a superstructure;
 - (1)(b) the hatchways are in the trunk deck, the hatchway coamings and covers comply with the requirements of

regulations 13 to 16 inclusive and the width of the trunk deck stringer provides a satisfactory gangway and sufficient lateral stiffness. However, small access openings with watertight covers may be permitted in the freeboard deck;

(1)(c) a permanent working platform fore and aft fitted with guard rails is provided by the trunk deck, or by detached trunks connected to superstructures by efficient permanent gangways;

(1)(d) ventilators are protected by the trunk, by watertight covers or by other equivalent means;

(1)(e) open rails are fitted on the weather parts of the freeboard deck in way of the trunk for at least half their length or, alternatively, freeing port area in the lower part of the bulwarks, subject to regulation 24(2), of 33% of the total area of the bulwarks is provided;

(1)(f) the machinery casings are protected by the trunk, by a superstructure of at least standard height, or by a deckhouse of the same height and of equivalent strength;

(1)(g) the breadth of the trunk is at least 60% of the breadth of the ship; and

(1)(h) where there is no superstructure, the length of the trunk is at least 0.6 L.

(2) The full length of an efficient trunk reduced in the ratio of its mean breadth to B shall be its effective length.

(3) The standard height of a trunk is the standard height of a superstructure other than a raised quarter deck.

(4) Where the height of a trunk is less than the standard height, its effective length shall be reduced in the ratio of the actual to the standard height. Where the height of hatchway coamings on the trunk deck is less than that required under regulation 14-1, a reduction from the actual height of trunk shall be made which corresponds to the difference between the actual and the required height of coaming.

(5) Where the trunk height is less than standard and the trunk hatch coamings are also of less than standard height, or omitted entirely, the reduction from the actual height of trunk on account of insufficient hatch coaming height shall be taken as the difference between 600 mm and the actual height of coaming, or 600 mm if no hatch coamings are fitted. Reduction in the actual height of trunk shall not be required in cases where only small hatches with less than standard height are fitted in the trunk deck for which dispensation from the requirement of standard coaming height may be given.

(6) Continuous hatchways may be treated as a trunk in the freeboard computation, provided the provisions of this paragraph are complied with in all respects.

The trunk deck stringer referred to in paragraph (1)(b) may be fitted outboard of the trunk side bulkhead in association with the following:

(6)(a) the stringer so formed is to provide a clear walkway of at least 450 mm in width on each side of the ship;

(6)(b) the stringer is to be of solid plate, efficiently supported and stiffened;

(6)(c) the stringer is to be as high above the freeboard deck as practicable. In the freeboard calculation, the trunk height is to be reduced by at least 600 mm or by the actual difference between the top of the trunk and the stringer, whichever is greater;

(6)(d) hatch cover securing appliances are to be accessible from the stringer or walkway; and

(6)(e) the breadth of the trunk is to be measured between the trunk side bulkheads.

(7) Where the trunk adjoining the superstructures such as poop, bridge or forecastle is included in the calculation of freeboard, openings shall not be arranged in that part of the bulkhead which is common for the trunk and superstructure. A relaxation may be made for small openings such as for piping, cable or manholes with covers attached by means of bolts.

(8) The sides of a trunk included in the calculation of freeboard shall be intact. Side scuttles of the non-opening type and bolted manhole covers may be allowed.

Regulation 37 Deduction for superstructures and trunks

(1) Where the effective length of superstructures and trunks is 1 L, the deduction from the freeboard shall be 350 mm at 24 m length of ship, 860 mm at 85 m length and 1070 mm at 122 m length and above. Deductions at intermediate lengths shall be obtained by linear interpolation.

(2) Where the total effective length of superstructures and trunks is less than 1 L, the deduction shall be a percentage obtained from the following table:

Table 37.1 - Percentage of deduction for type 'A' and 'B' ships

	<i>Total Effective Length of Superstructures and Trunks</i>										
	0	0.1L	0.2L	0.3L	0.4L	0.5L	0.6L	0.7L	0.8L	0.9L	1.0L
Percentage of deduction for all types of super-	0	7	14	21	31	41	52	63	75.3	87.7	100

<i>structures</i>										
Percentages at intermediate lengths of superstructures and trunks shall be obtained by linear interpolation.										

(3) For ships of type 'B' where the effective length of a forecastle is less than 0.07L no deduction is allowed.

Regulation 38 Sheer

General

- (1) The sheer shall be measured from the deck at side to a line of reference drawn parallel to the keel through the sheer line amidships.
- (2) In ships designed with a rake of keel, the sheer shall be measured in relation to a reference line drawn parallel to the design load waterline.
- (3) In flush deck ships and in ships with detached superstructures the sheer shall be measured at the freeboard deck.
- (4) In ships with topsides of unusual form in which there is a step or break in the topsides, the sheer shall be considered in relation to the equivalent depth amidships.
- (5) In ships with a superstructure of standard height which extends over the whole length of the freeboard deck, the sheer shall be measured at the superstructure deck. Where the height exceeds the standard, the least difference (Z) between the actual and standard heights shall be added to each end ordinate. Similarly, the intermediate ordinates at distances of 1/6 L and 1/3 L from each perpendicular shall be increased by 0.444Z and 0.111Z, respectively. Where there is an enclosed poop or forecastle superimposed on the superstructure, sheer credit shall be allowed for such a poop or forecastle, according to the method of paragraph (12) as shown in figure 38.1.

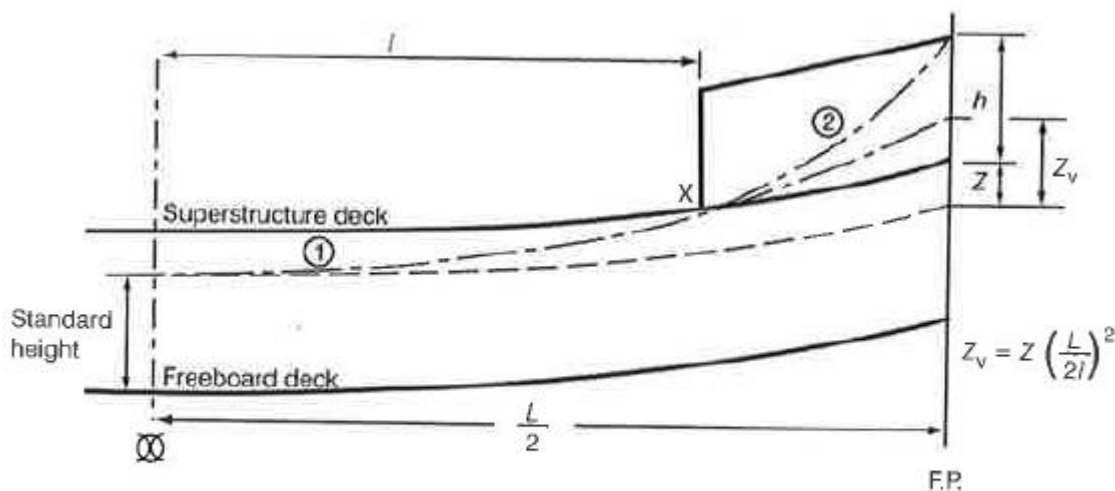

Figure 38.1

- (6) Where the deck of an enclosed superstructure has at least the same sheer as the exposed freeboard deck, the sheer of the enclosed portion of the freeboard deck shall not be taken into account.
- (7) Where an enclosed poop or forecastle is of standard height with greater sheer than that of the freeboard deck, or is of more than standard height, an addition to the sheer of the freeboard deck shall be made as provided in paragraph (12).

Where a poop or forecastle consists of two layers, the method shown in figure 38.2 shall be used.

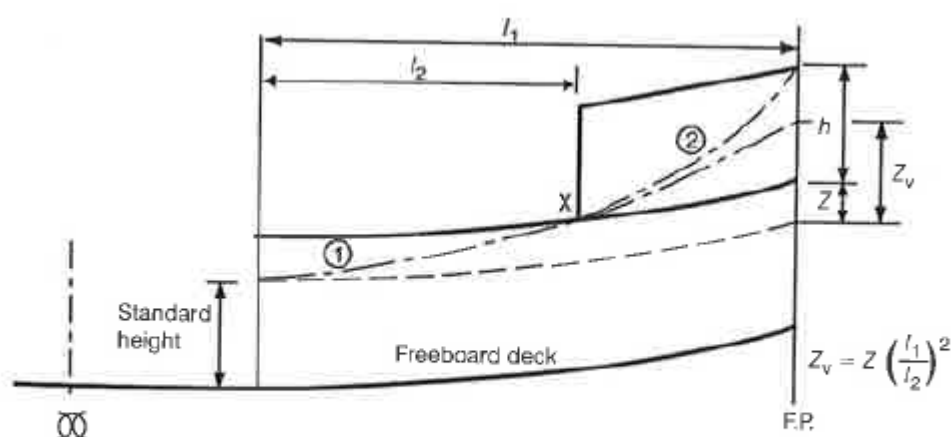

Figure 38.2

In figures 38.1 and 38.2, the following definitions apply:

Z is as defined in paragraph (5); and

Z_v is the end ordinate of a virtual standard parabolic curve taken through the point "X". If Z_v is greater than $(Z + h)$, the end ordinate shall be $(Z + h)$, in which case point "X" shall be disregarded and curve (2) not taken into account.

When the length of the first tier superstructure is greater than 0.5 l, the virtual standard parabolic curve shall commence at amidships as indicated in figure 38.1.

Standard shear profile

(8) The ordinates of the standard shear profile are given in the following table:

Table 38.1

Standard shear profile

(where L is in m)

	Station	Ordinate (in mm)	Factor
After half	After perpendicular	25 (L/3 + 10)	1
	1/6 L from A.P.	11.1 (L/3 + 10)	3
	1/3 L from A.P.	2.8 (L/3 + 10)	3
	Amidships	0	1
Forward half	Amidships	0	1
	1/3 L from F.P.	5.6 (L/3 + 10)	3
	1/6 L from F.P.	22.2 (L/3 + 10)	3
	Forward perpendicular	50 (L/3 + 10)	1

Measurement of variation from standard shear profile

(9) Where the shear profile differs from the standard, the four ordinates of each profile in the forward or after half shall be multiplied by the appropriate factors given in the above table in regulation 8 of ordinates. The difference between the sums of the respective products and those of the standard divided by 8 measures the deficiency or excess of shear in the forward or after half. The arithmetical mean of the excess or deficiency in the forward and after halves measures the excess or deficiency of shear.

(10) Where the after half of the shear profile is greater than the standard and the forward half is less than the standard, no credit shall be allowed for the part in excess and deficiency only shall be measured.

(11) Where the forward half of the shear profile exceeds the standard, and the after portion of the shear profile is not less than 75% of the standard, credit shall be allowed for the part in excess. Where the after part is less than 50% of the standard no credit shall be given for the excess shear forward. Where the after shear is between 50%

and 75% of the standard, intermediate allowances may be granted for excess sheer forward.

(12) Where sheer credit is given for a poop or forecastle the following formula shall be used:

$$S = y L' / 3L$$

where:

s is the sheer credit, to be deducted from the deficiency, or added to the excess of sheer;

y is the difference between actual and standard height of superstructure at the after or forward perpendicular;

L' is the mean enclosed length of poop or forecastle up to a maximum length of 0.5 L; and

L is the length of the ship as defined in regulation 3(1).

The above formula provides a curve in the form of a parabola tangent to the actual sheer curve at the freeboard deck and intersecting the end ordinate at a point below the superstructure deck a distance equal to the standard height of a superstructure. The superstructure deck shall not be less than standard height above this curve at any point. This curve shall be used in determining the sheer profile for forward and after halves of the ship.

(13) (a) Any excess in the height of a superstructure which does not extend to the after perpendicular cannot be regarded as contributing to the sheer allowance.

(13)(b) Where the height of a superstructure is less than standard, the superstructure deck shall not be less than the minimum height of the superstructure above the virtual sheer curve at any point. For this purpose y shall be taken as the difference between the actual and minimum height of the superstructure at the after/forward perpendicular

(13)(c) For a raised quarterdeck credit may be given only when the height of this quarterdeck is greater than the standard height of 'other superstructures' as defined in regulation 33, and only for the amount by which the actual height of the raised quarterdeck exceeds that standard height.

(13)(d) When a poop or a forecastle has sloping end bulkheads, the sheer credit may be allowed on account of excess height. The formula given in paragraph (12) shall be used, the values for y and L' being as shown in figure 38.3

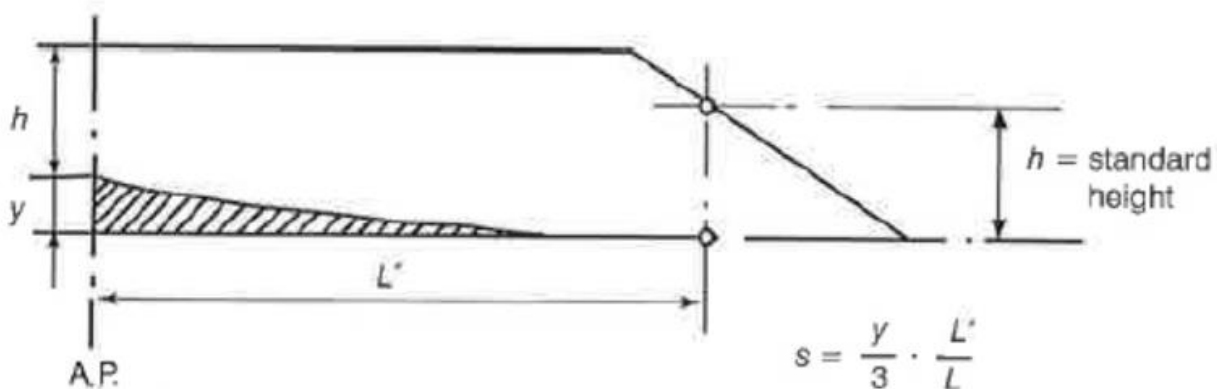

Figure 38.3

Correction for variations from standard sheer profile

(14) The correction for sheer shall be the deficiency or excess of sheer (see paragraphs (9) to (12) inclusive), multiplied by

$$0.75 - S_1/2L$$

where S_1 is the total length S of enclosed superstructures as defined in regulation 34 without trunks.

Addition for deficiency in sheer

(15) Where the sheer is less than the standard, the correction for deficiency in sheer (see paragraph (14)) shall be added to the freeboard.

Deduction for excess sheer

(16) In ships where an enclosed superstructure covers 0.1 L before and 0.1 L abaft amidships, the correction for excess of sheer as calculated under the provisions of paragraph (14) shall be deducted from the freeboard; in ships where no enclosed superstructure covers amidships, no deduction shall be made from the freeboard; where an enclosed superstructure covers less than 0.1L before and 0.1L abaft amidships, the deduction shall be obtained by linear interpolation. The maximum deduction for excess sheer shall be at the rate of 125 mm per

100 m of length.

In applying this paragraph, the height of the superstructure shall be related to its standard height. Where the height of the superstructure or raised quarterdeck is less than standard, the reduction shall be in the ratio of the actual to the standard height thereof.

Regulation 39 Minimum bow height and reserve buoyancy

(1) The bow height (F_b), defined as the vertical distance at the forward perpendicular between the waterline corresponding to the assigned summer freeboard and the designed trim and the top of the exposed deck at side, shall be not less than:

$$F_b = [6075(L/100) - 1875(L/100)^2 + 200(L/100)^3] \cdot [2.08 + 0.609C_b - 1.603C_{wf} - 0.0129(L/d_1)]$$

where:

F_b is the calculated minimum bow height, in mm;

L is the length, as defined in regulation 3, in m;

B is the moulded breadth, as defined in regulation 3, in m;

d_1 is the draught at 85% of the least moulded depth, in metres;

C_b is the block coefficient, as defined in regulation 3;

C_{wf} is the waterplane area coefficient forward of $L/2$:

$$C_{wf} = A_{wf} / \{(L/2) \cdot B\};$$

A_{wf} is the waterplane area forward of $L/2$ at draught d_1 , in m^2 .

For ships to which **timber** freeboards are assigned, the summer freeboard (and not the timber summer freeboard) is to be assumed when applying paragraph (1).

(2) Where the bow height required in paragraph (1) is obtained by sheer, the sheer shall extend for at least 15% of the length of the ship measured from the forward perpendicular. Where it is obtained by fitting a superstructure, such superstructure shall extend from the stem to a point at least 0.07 L abaft the forward perpendicular, and shall be enclosed as defined in regulation 3(10).

(3) Ships which, to suit exceptional operational requirements, cannot meet the requirements of paragraphs (1) and (2) of this regulation may be given special consideration by the Administration.

(4)(a) The sheer of the forecastle deck may be taken into account, even if the length of the forecastle is less than 0.15 L , but greater than 0.07 L , provided that the forecastle height is not less than one half of standard height of superstructure as defined in regulation 33 between 0.07 L and the forward perpendicular.

(4)(b) Where the forecastle height is less than one half of the standard height of superstructure, as defined in regulation 33, the credited bow height may be determined as follows:

(4)(b)(i) Where the freeboard deck has sheer extending from abaft 0.15 L , by a parabolic curve having its origin at 0.15 L abaft the forward perpendicular at a height equal to the midship depth of the ship, extended through the point of intersection of forecastle bulkhead and deck, and up to a point at the forward perpendicular not higher than the level of the forecastle deck (as illustrated in figure 39.1). However, if the value of the height denoted h_t in figure 39.1 is smaller than the value of the height denoted h_b then h_t may be replaced by h_b in the available bow height.

(4)(b)(ii) Where the freeboard deck has sheer extending for less than 0.15 L or has no sheer, by a line from the forecastle deck at side at 0.07 L extended parallel to the base line to the forward perpendicular (as illustrated in figure 39.2).

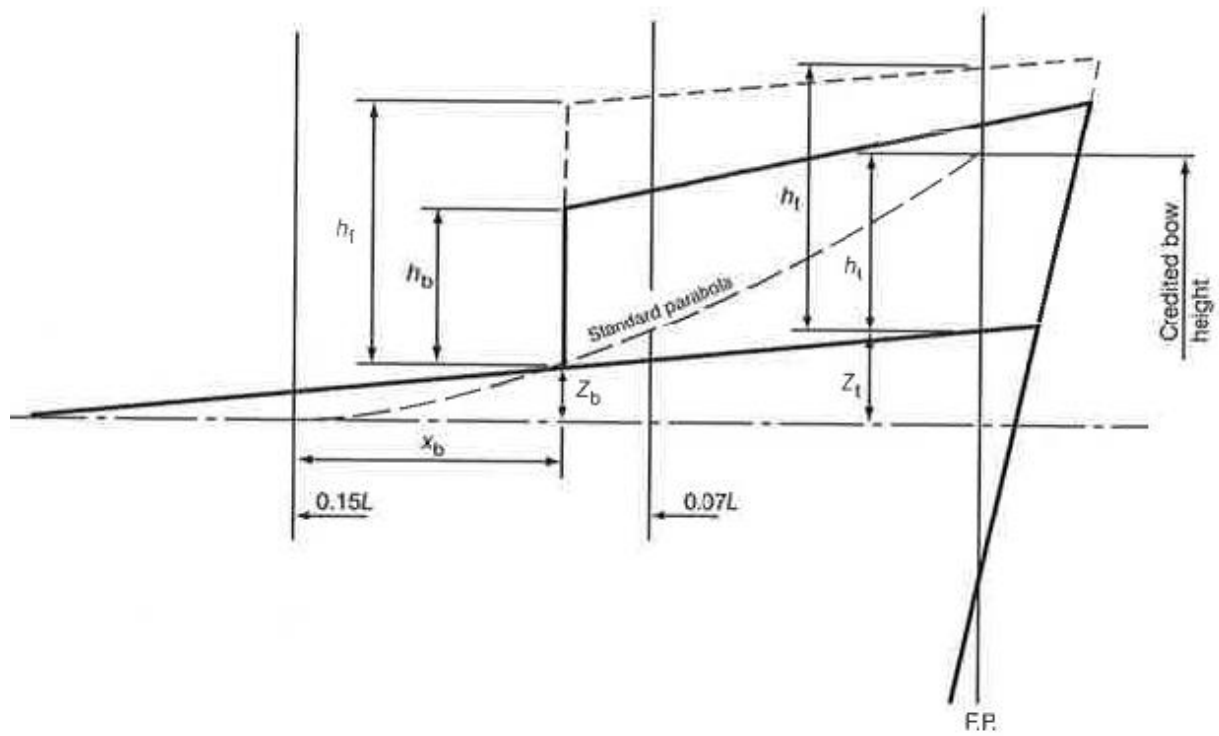

Figure 39.1

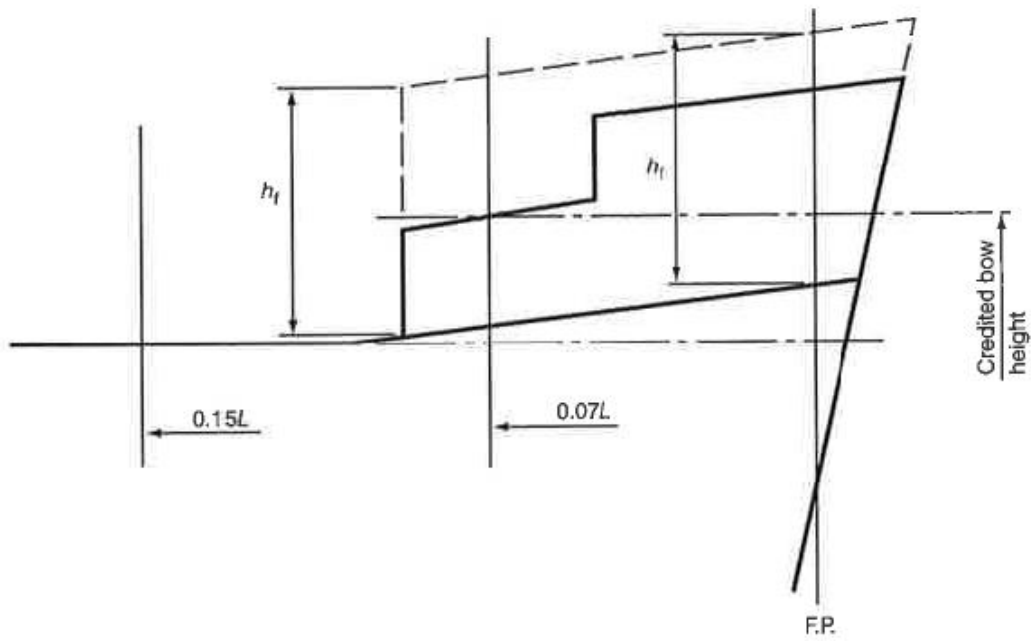

Figure 39.2

h_f = Half standard height of superstructure as defined in regulation 33.

(5) All ships assigned a type 'B' freeboard, other than oil tankers^{v)}, chemical tankers^{v)} and gas carriers⁵⁾, shall have additional reserve buoyancy in the fore end. Within the range of 0.15 L abaft of the forward perpendicular, the sum of the projected area between the summer load waterline and the deck at side (A1 and A2 in figure 39.3) and the projected area of an enclosed superstructure, if fitted, (A3) shall not be less than:

$$[0.15 \cdot F_{\min} + 4 \cdot (L/3 + 10)] \cdot L/1000 \text{ (m}^2\text{)},$$

where:

F_{\min} is calculated by: $F_{\min} = (F_0 \cdot f_1) + f_2$;

F_0 is the tabular freeboard, in mm, taken from table 28.2, corrected for regulation 27(9) or 27(10), as applicable;

f_1 is the correction for block coefficient given in regulation 30; and

f_2 is the correction for depth, in mm, given in regulation 31 .

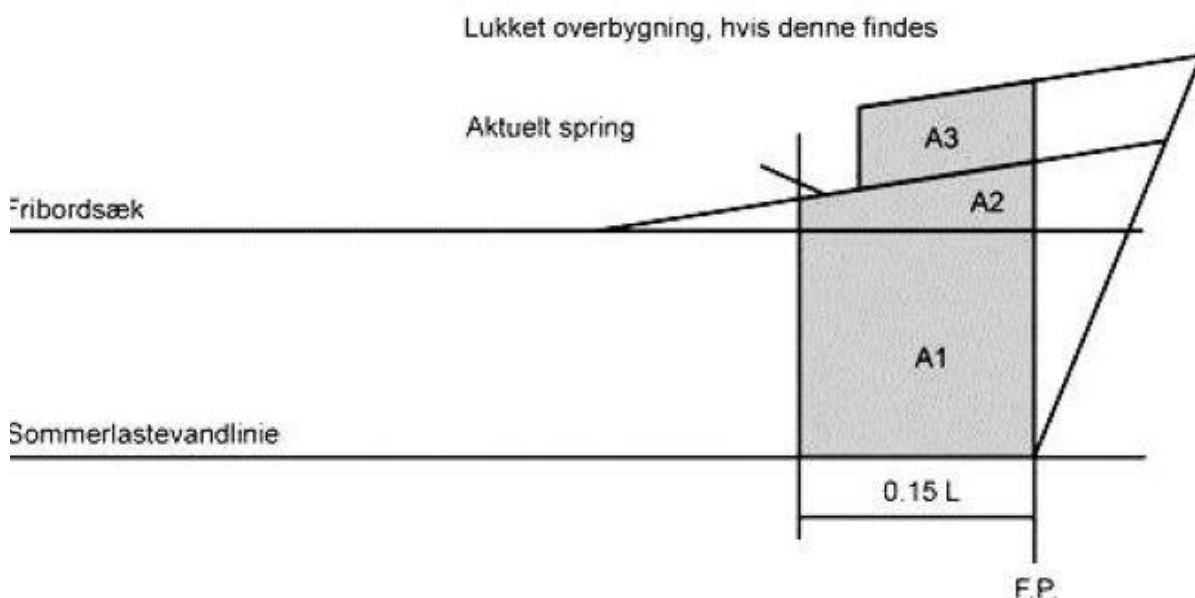

Figure 39.3

Regulation 40 Minimum freeboards

Summer freeboard

(1) The minimum freeboard in summer shall be the freeboard derived from the tables in regulation 28, as modified by the corrections in regulations 27, as applicable, 29, 30, 31, 32, 37, 38 and, if applicable, 39.

(2) The freeboard in salt water, as calculated in accordance with paragraph (1), but without the correction for deck line, as provided by regulation 32, shall not be less than 50 mm. For ships having in position 1 hatchways with covers which do not comply with the requirements of regulation 16(1) through (5) or regulation 26, the freeboard shall be not less than 150 mm.

Tropical freeboard

(3) The minimum freeboard in the Tropical Zone shall be the freeboard obtained by a deduction from the summer freeboard of one forty-eighth of the summer draught measured from the top of the keel to the centre of the ring of the load line mark.

(4) The freeboard in salt water, as calculated in accordance with paragraph (3), but without the correction for deck line, as provided by regulation 32, shall not be less than 50 mm. For ships having in position 1 hatchways with covers which do not comply with the requirements of regulation 16(1) through (5) or regulation 26, the freeboard shall be not less than 150 mm.

Winter freeboard

(5) The minimum freeboard in winter shall be the freeboard obtained by an addition to the summer freeboard of one forty-eighth of summer draught, measured from the top of the keel to the centre of the ring of the load line mark.

Winter North Atlantic freeboard

(6) The minimum freeboard for ships of not more than 100 m in length which enter any part of the North Atlantic defined in regulation 52 (Annex II) during the winter seasonal period shall be the winter freeboard plus 50 mm. For other ships, the winter North Atlantic freeboard shall be the winter freeboard.

Fresh water freeboard

(7) The minimum freeboard in fresh water of unit density shall be obtained by deducting from the minimum freeboard in salt water:

$$\Delta/(40 \cdot T) \text{ (cm)}$$

where:

Δ is the displacement in salt water in tonnes at the summer load waterline; and
T is the tonnes per centimetre immersion in salt water at the summer load waterline.

(8) Where the displacement at the summer load waterline cannot be certified, the deduction shall be one forty-eight of summer draught, measured from the top of the keel to the centre of the ring of the load line mark.

Annex I

Regulations for determining load lines

Chapter IV

Special requirements for ships assigned timber freeboards

Regulation 41 Application of this chapter

Regulations 42 to 45 inclusive apply only to ships to which timber load lines are assigned.

Regulation 42 Definitions

(1) *Timber deck cargo.*

The term "*timber deck cargo*" means a cargo of timber carried on an uncovered part of a freeboard deck. The term does not include wood pulp or similar cargo^{vi)}

(2) *Timber load line.*

A timber deck cargo may be regarded as giving a ship a certain additional buoyancy and a greater degree of protection against the sea. For that reason, ships carrying a timber deck cargo may be granted a reduction of freeboard calculated according to the provisions of regulation 45 and marked on the ship's side in accordance with the provisions of regulations 6(3) and (4). However, in order that such special freeboard may be granted and used, the timber deck cargo shall comply with certain conditions which are laid down in regulation 44, and the ship itself shall also comply with certain conditions relating to its construction which are set out in regulation 43.

Regulation 43 Construction of the ship

Superstructure

(1) Ships shall have a forecastle of at least standard height and a length of at least 0.07 L. In addition, if the ship is less than 100 m in length, a poop of at least standard height, or a raised quarterdeck with a deckhouse of at least the same total height shall be fitted aft.

Double bottom tanks

(2) Double bottom tanks, where fitted within the midship half length of the ship, shall have adequate watertight longitudinal subdivision.

Bulwarks

(3) The ship shall be fitted either with permanent bulwarks at least 1 m in height, specially stiffened on the upper edge and supported by strong bulwark stays attached to the deck and provided with necessary freeing

ports, or with efficient rails of the same height and of specially strong construction.

Regulation 44 Stowage

General

(1) Openings in the deck exposed to weather over which cargo is stowed shall be securely closed and battened down.

The ventilators and air pipes shall be efficiently protected.

(2) Timber deck cargoes shall extend over at least the entire available length which is the total length of the well or wells between superstructures.

Where there is no limiting superstructure at the after end, the timber shall extend at least to the after end of the aftermost hatchway.

The timber deck cargo shall extend athwartships as close as possible to the ship's side, due allowance being made for obstructions such as guard rails, bulwark stays, uprights, pilot access, etc., provided that any gap thus created at the side of the ship shall not exceed a mean of 4% of the breadth. The timber shall be stowed as solidly as possible to at least the standard height of the superstructure other than any raised quarterdeck.

(3) On a ship within a seasonal winter zone in winter, the height of the deck cargo above the deck exposed to weather shall not exceed one third of the extreme breadth of the ship.

(4) The timber deck cargo shall be compactly stowed, lashed and secured. It shall not interfere in any way with the navigation and necessary work of the ship.

Uprights

(5) Uprights, when required by the nature of the timber, shall be of adequate strength considering the breadth of the ship; the strength of the uprights shall not exceed the strength of the bulwark and the spacing shall be suitable for the length and character of timber carried, but shall not exceed 3 m. Strong angles or metal sockets or equally efficient means shall be provided for securing the uprights.

Lashings

(6) Timber deck cargo shall be effectively secured throughout its length by a lashing system acceptable to the Administration for the character of the timber carried ^{vi)}

Stability

(7) Provision shall be made for a safe margin of stability at all stages of the voyage, regard being given to additions of weight, such as those arising from absorption of water or icing, if applicable, and to losses of weight such as those arising from consumption of fuel and stores.

Protection of crew, access to machinery spaces, etc.

(8) In addition to the requirements of regulation 25(5), guard-rails or lifelines not more than 350 mm apart vertically shall be provided on each side of the cargo deck to a height of at least 1 m above the cargo.

In addition a lifeline, preferably wire rope set up taut with a stretching screw, shall be provided as near as practicable to the centreline of the ship. The stanchion supports to all guard-rails and lifelines shall be so spaced as to prevent undue sagging. Where the cargo is uneven, a safe walking surface of not less than 600 mm in width shall be fitted over the cargo and effectively secured beneath or adjacent to the lifeline.

(9) Where the requirements prescribed in paragraph (8) are impracticable, alternative arrangements satisfactory to the Administration shall be used.

Steering arrangements

(10) Steering arrangements shall be effectively protected from damage by cargo and, as far as practicable, shall be accessible. Efficient provision shall be made for steering in the event of a breakdown in the main steering arrangements.

Regulation 45 Computation for freeboard

(1) The minimum summer freeboards shall be computed in accordance with regulations 27(5), 27(6), 27(14), 28,29,30,31,32,37 and 38, except that regulation 37 is modified by substituting the following percentages for those given in regulation 37:

Table 45.1

Table 45.1 - Total effective length of superstructure

	0	0.1L	0.2L	0.3L	0.4L	0.5L	0.6L	0.7L	0.8L	0.9L	1.0L
Percentage of deduction for all types of structures	20	31	42	53	64	70	76	82	88	94	100
Percentages at intermediate lengths of superstructure shall be obtained by linear interpolation.											

- (2) The Winter Timber Freeboard shall be obtained by adding to the Summer Timber Freeboard one thirty-sixth of the moulded summer timber draught.
- (3) The Winter North Atlantic Timber Freeboard shall be the same as the Winter North Atlantic Freeboard prescribed in regulation 40(6).
- (4) The Tropical Timber Freeboard shall be obtained by deducting from the Summer Timber Freeboard one forty-eighth of the moulded summer timber draught.
- (5) The Fresh Water Timber Freeboard shall be computed in accordance with regulation 40(7), based on the summer timber load waterline or with regulation 40(8), based on the summer timber draught measured from the top of the keel to the summer timber load line.
- (6) Timber freeboards may be assigned to ships with reduced type 'B' freeboards, provided the timber freeboards are calculated on the basis of the ordinary type 'B' freeboard.
- (7) The Timber Winter mark and/or the Timber Winter North Atlantic mark shall be placed at the same level as the reduced type 'B' Winter mark when the computed Timber Winter mark and/or the computed Timber Winter North Atlantic mark fall below the reduced type 'B' Winter mark.

ANNEX II

Zones, Areas and seasonal periods

The zones and areas in this Annex are, in general, based on the following criteria:

Summer zones and areas:

- not more than 10 per cent winds of force 8 Beaufort (34 knots) or more

Tropical zones and areas:

- not more than 1 per cent winds of force 8 (Beaufort) (34 knots) or more. Not more than one tropical storm in 10 years in an area of 5 degrees square in any one separate calendar month.

In certain special areas, for practical reasons, some degree of relaxation has been found acceptable.

A chart is attached to this Annex to illustrate the zones and areas defined below.

Regulation 46 Northern winter seasonal zones and area

(1) North Atlantic Winter Seasonal Zones I and II

(1)(a) The North Atlantic Winter Seasonal Zone I lies within the meridian of longitude 50°W from the coast of Greenland to latitude 45°N, thence the parallel of latitude 45°N to longitude 15°W, thence the meridian of longitude 15°W to latitude 60°N, thence the parallel of latitude 60°N to the Greenwich Meridian, thence this meridian northwards.

Seasonal periods :

WINTER: 16 October to 15 April.

SUMMER: 16 April to 15 October.

(1)(b) The North Atlantic Winter Seasonal Zone II lies within the meridian of longitude 68°30' W from the coast of the United States to latitude 40°N, thence the rhumb line to the point latitude 36°N, longitude 73°W, thence the parallel of latitude 36°N to longitude 25°W and thence the rhumb line to Cape Torinana.

Excluded from this zone are the North Atlantic winter seasonal zone I, the North Atlantic winter seasonal area and the Baltic Sea bounded by the parallel of latitude of the Skaw in the Skagerrak. The Shetland Islands are to

be considered as being on the boundary of the North Atlantic winter seasonal zones I and II.

Seasonal periods :

WINTER: 1 November to 31 March.

SUMMER: 1 April to 31 October.

(2) North Atlantic Winter Seasonal Area

The boundary of the North Atlantic Winter Seasonal Area is

- the meridian of longitude 68°30' W from the coast of the United States to latitude 40°N, thence the rhumb line to the southernmost intersection of the meridian of longitude 61°W with the coast of Canada and thence the east coasts of Canada and the United States.

Seasonal periods :

For ships over 100 metres (328 feet) in length:

WINTER: 16 December to 15 February.

SUMMER : 16 February to 15 December.

For ships of 100 metres (328 feet) and under in length:

WINTER: 1 November to 31 March.

SUMMER : 1 April to 31 October.

(3) North Pacific Winter Seasonal Zone

The southern boundary of the North Pacific Winter Seasonal Zone is

- the parallel of latitude 50°N from the east coast of the USSR to the west coast of Sakhalin, thence the west coast of Sakhalin to the southern extremity of Cape Kurilion, thence the rhumb line to Wakkanai, Hokkaido, Japan, thence the east and south coasts of Hokkaido to longitude 145°E, thence the meridian of longitude 145°E to latitude 35°N, thence the Parallel of latitude 35°N to longitude 150°W and thence the rhumb line to the southern extremity of Dall Island, Alaska.

Seasonal periods :

WINTER: 16 October to 15 April.

SUMMER: 16 April to 15 October.

Regulation 47 Southern winter seasonal zone

The northern boundary of the Southern Winter Seasonal Zone is –

"The rhumb line from the east coast of the American continent at Cape Tres Puntas to the point latitude 34° S, longitude 50° W, thence the parallel of latitude 34° S to longitude 16° E, thence the rhumb line to the point latitude 36° S, longitude 20° E, thence the rhumb line to the point latitude 34° S, longitude 30° E, thence along the rhumb line to the point latitude 35° 30' S, longitude 118° E, and thence the rhumb line to Cape Grim on the north-west coast of Tasmania; thence along the north and east coasts of Tasmania to the southernmost point of Bruny Island, thence the rhumb line to Black Rock Point on Stewart Island, thence the rhumb line to the point latitude 47° S, longitude 170° E, thence along the rhumb line to the point latitude 33° S, longitude 170° W, and thence the parallel of latitude 33° S to the point latitude 33° S, longitude 79° W, thence the rhumb line to the point latitude 41° S, longitude 75° W, thence the rhumb line to Punta Corona lighthouse on Chiloe Island, latitude 41°47' S, longitude 73°53' W, thence along the north, east and south coasts of Chiloe Island to the point latitude 43°20' S, longitude 74°20' W, and thence the meridian of longitude 74°20' W to the parallel of latitude 45°45' S, including the inner zone of Chiloe channels from the meridian 74°20' W to the east.

Seasonal periods :

WINTER: 16 April to 15 October.

SUMMER: 16 October to 15 April.

Regulation 48 Tropical Zone

(1) Northern Boundary of the Tropical Zone

The northern boundary of the Tropical Zone is –

the parallel of latitude 13°N from the east coast of the American continent to longitude 60°W, thence the rhumb line to the point latitude 10°N, longitude 58°W, thence the parallel of latitude 10°N to longitude 20°W, thence the meridian of longitude 20°W to latitude 30°N and thence the parallel of latitude 30°N to the west coast of Africa; from the east coast of Africa the parallel of latitude 8°N to longitude 70°E, thence the meridian of longitude 70°E to latitude 13°N, thence the parallel of latitude 13°N to the west coast of India; thence the south coast of India to latitude 10°30' N on the east coast of India, thence the rhumb line to the point latitude 9°N,

longitude 82°E, thence the meridian of longitude 82°E to latitude 8°N, thence the parallel of latitude 8°N to the west coast of Malaysia, thence the coast of South-East Asia to the east coast of Viet-Nam at latitude 10°N, thence the parallel of latitude 10°N to longitude 145°E, thence the meridian of longitude 145°E to latitude 13°N and thence the parallel of latitude 13°N to the west coast of the American continent.

Saigon is to be considered as being on the boundary line of the Tropical Zone and the Seasonal Tropical Area.

(2) Southern Boundary of the Tropical Zone

The southern boundary of the Tropical Zone is –

the rhumb line from the Port of Santos, Brazil, to the point where the meridian of longitude 40°W intersects the Tropic of Capricorn; thence the Tropic of Capricorn to the west coast of Africa; from the east coast of Africa the parallel of latitude 20°S to the west coast of Madagascar, thence the west and north coasts of Madagascar to longitude 50°E, thence the meridian of longitude 50°E to latitude 10°S, thence the parallel of latitude 10°S to longitude 98°E, thence the rhumb line to Port Darwin, Australia, thence the coasts of Australia and Wessel Island eastwards to Cape Wessel, thence the parallel of latitude 11°S to the west side of Cape York; from the east side of Cape York the parallel of latitude 11°S to longitude 150°W, thence the rhumb line to the point latitude 26°S, longitude 75°W, thence the rhumb line to the point latitude 32°47' S, longitude 72°W, and thence to the parallel of latitude 32°47' S to the west coast of South America.

Valparaiso and Santos are to be considered as being on the boundary line of the Tropical and Summer Zones.

(3) Areas to be included in the Tropical Zone

The following areas are to be treated as included in the Tropical Zone -

(3)(a) The Suez Canal, the Red Sea and the Gulf of Aden, from Port Said to the meridian of longitude 45°E. Aden and Berbera are to be considered as being on the boundary line to the Tropical Zone and the Seasonal Tropical Area.

(3)(b) The Persian Gulf to the meridian of longitude 59°E.

(3)(c) The area bounded by the parallel of latitude 22°S from the east coast of Australia to the Great Barrier Reef, thence the Great Barrier Reef to latitude 11°S. The northern boundary of the area is the southern boundary of the Tropical Zone.

Regulation 49 Seasonal tropical areas

The following are Seasonal Tropical Areas:

(1) In the North Atlantic

An area bounded -

on the north by the rhumb line from Cape Catoche, Yucatan, to Cape San Antonio, Cuba, the north coast of Cuba to latitude 20°N and thence the parallel of latitude 20°N to longitude 20°W; on the west by the coast of the American continent;

on the south and east by the northern boundary of the Tropical Zone.

Seasonal periods:

TROPICAL: 1 November to 15 July.

SUMMER: 16 July to 31 October.

(2) In the Arabian Sea

An area bounded -

on the west by the coast of Africa, the meridian of longitude 45°E in the Gulf of Aden, the coast of South Arabia and the meridian of longitude 59°E in the Gulf of Oman;

on the north and east by the coasts of Pakistan and India; on the south by the northern boundary of the Tropical Zone.

Seasonal periods :

TROPICAL: 1 September to 31 May.

SUMMER: 1 June to 31 August.

(3) In the Bay of Bengal

The Bay of Bengal north of the northern boundary of the Tropical Zone.

Seasonal periods :

TROPICAL: 1 December to 30 April.

SUMMER: 1 May to 30 November.

(4) In the South Indian Ocean

(4)(a) An area bounded -

on the north and west by the southern boundary of the Tropical Zone and the east coast of Madagascar; on the south by the parallel of latitude 20°S;
on the east by the rhumb line from the point latitude 20°S, longitude 50°E, to the point latitude 15°S, longitude 51°30' E, and thence by the meridian of longitude 51°30' E to latitude 10°S.

Seasonal periods :

TROPICAL: 1 April to 30 November.

SUMMER: 1 December to 31 March.

(4)(b) An area bounded -

on the north by the southern boundary of the Tropical Zone; on the east by the coast of Australia; on the south by the parallel of latitude 15°S from longitude 51°30' E, to longitude 114°E and thence the meridian of longitude 114°E to the coast of Australia, on the west of the meridian of longitude 51°30' E

Seasonal periods :

TROPICAL: 1 May to 30 November.

SUMMER : 1 December to 30 April.

(5) In the China Sea.

An area bounded -

on the west and north by the coasts of Viet-Nam and China from latitude 10°N to Hong Kong;
on the east by the rhumb line from Hong Kong to the Port of Sual (Luzon Island) and the west coasts of the Islands of Luzon, Samar and Leyte to latitude 10°N;
on the south by the parallel of latitude 10°N. Hong Kong and Sual are to be considered as being on the boundary of the Seasonal Tropical Area and Summer Zone.

Seasonal periods :

TROPICAL: 21 January to 30 April.

SUMMER: 1 May to 20 January.

(6) In the North Pacific.

(6)(a) An area bounded -

on the north by the parallel of latitude 25°N; on the west by the meridian of longitude 160°E; on the south by the parallel of latitude 13°N;
on the east by the meridian of longitude 130°W.

Seasonal periods :

TROPICAL: 1 April to 31 October.

SUMMER: 1 November to 31 March.

(6)(b) An area bounded –

on the north and east by the west coast of the American continent; on the west by the meridian of longitude 123°W from the coast of the American continent to latitude 33°N and by the rhumb line from the point latitude 33°N, longitude 123°W, to the point latitude 13°N, longitude 105°W;
on the south by the parallel of latitude 13°N.

Seasonal periods :

TROPICAL: 1 March to 30 June and 1 November to 30 November.

SUMMER: 1 July to 31 October and 1 December to 28/29 February.

(7) In the South Pacific.

(7)(a) The Gulf of Carpentaria south of latitude 11°S

Seasonal periods :

TROPICAL: 1 April to 30 November.

SUMMER: 1 December to 31 March.

(7)(b) An area bounded:

on the north and east by the southern boundary of the Tropical Zone;
on the south by the parallel of latitude of 24°S from the east coast of Australia to longitude 154°E, thence by the meridian of longitude 154°E to the Tropic of Capricorn and thence by the Tropic of Capricorn to longitude 150°W, thence by the meridian of longitude 150°W to latitude 20°S and thence by the parallel of latitude 20°S to the point where it intersects the southern boundary of the Tropical Zone;
on the west by the boundaries of the area within the Great Barrier Reef included in the Tropical Zone and by the east coast of Australia.

Seasonal periods:

TROPICAL: 1 April to 30 November
SUMMER: 1 December to 31 March.

Regulation 50 Summer zones

The remaining areas constitute the Summer Zones.

However, for ships of 100 metres (328 feet) and under in length, the area bounded -
on the north and west by the east coast of the United States; on the east by the meridian of longitude 68°30' W
from the coast of the United States to latitude 40°N and thence by the rhumb line to the point latitude 36°N,
longitude 73°W;

on the south by the parallel of latitude 36°N;
is a Winter Seasonal Area.

Seasonal periods:

WINTER: 1 November to 31 March.

SUMMER: 1 April to 31 October.

Regulation 51 Enclosed seas

(1) Baltic Sea

This sea bounded by the parallel of latitude of The Skaw in the Skagerrak is included in the Summer Zones.
However, for ships of 100 metres (328 feet) and under in length, it is a Winter Seasonal Area.

Seasonal periods :

WINTER: 1 November to 31 March.

SUMMER : 1 April to 31 October.

(2) Black Sea

This sea is included in the Summer Zones.

However, for ships of 100 metres (328 feet) and under in length, the area north of latitude 44N is a Winter
Seasonal Area.

Seasonal periods :

WINTER : 1 December to 28/29 February.

SUMMER: 1 March to 30 November.

(3) Mediterranean

This sea is included in the Summer Zones.

However, for ships of 100 metres (328 feet) and under in length, the area bounded -
on the north and west by the coasts of France and Spain and the meridian of longitude 3°E from the coast of
Spain to latitude 40°N;

on the south by the parallel of latitude 40°N from longitude 3°E to the west coast of Sardinia;

on the east by the west and north coasts of Sardinia from latitude 40°N to longitude 9°E, thence by the meridian
of longitude 9°E to the south coast of Corsica, thence by the west and north coasts of Corsica to longitude 9°E
and thence by the rhumb line to Cape Sicie;

is a Winter Seasonal Area.

Seasonal periods :

WINTER: 16 December to 15 March.

SUMMER: 16 March to 15 December.

(4) Sea of Japan

This sea south of latitude 50°N is included in the Summer Zones.

However, for ships of 100 metres (328 feet) and under in length, the area between the parallel of latitude 50°N
and the rhumb line from the east coast of Korea at latitude 38°N to the west coast of Hokkaido, Japan, at
latitude 43°12' N is a Winter Seasonal Area.

Seasonal periods :

WINTER: 1 December to 28/29 February.

SUMMER: 1 March to 30 November.

Regulation 52 The winter North Atlantic load line

The part of the North Atlantic referred to in regulation 40(6) comprises :

(a) that part of the North Atlantic Winter Seasonal Zone II which lies between the meridians of 15°W and
50°W;

(b) the whole of the North Atlantic Winter Seasonal Zone I, the Shetland Islands to be considered as being on the boundary.

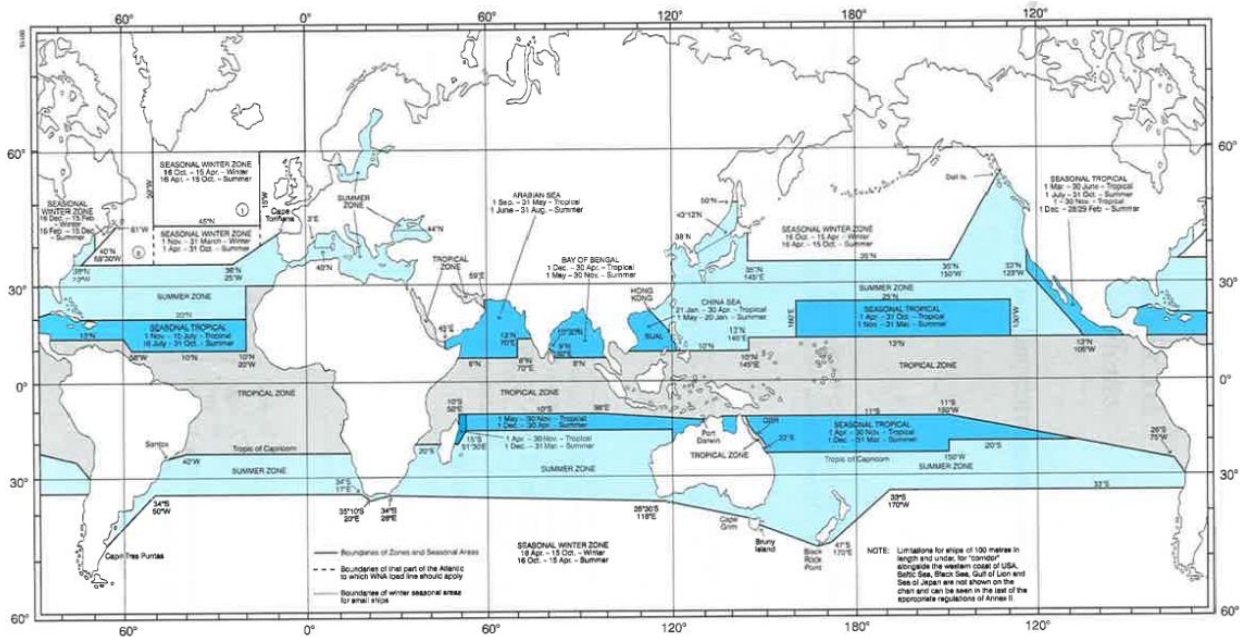

Chart of Zones and Seasonal Areas

ANNEX III
Certificates

An overview of relevant updated certificates is available on the Danish Maritime Authority’s website.

ANNEX IV

Verification of compliance with the provisions of this convention

Regulation 53 Application

Contracting Governments shall use the provisions of the Code for Implementation in the execution of their obligations and responsibilities contained in the present Convention.

Regulation 54 Verification of compliance

- (1) Every Contracting Government shall be subject to periodic audits by the Organization in accordance with the audit standard to verify compliance with and implementation of the present Convention.
- (2) The Secretary-General of the Organization shall have responsibility for administering the Audit Scheme, based on the guidelines developed by the Organization^{vii)}
- (3) Every Contracting Government shall have responsibility for facilitating the conduct of the audit and implementation of a programme of actions to address the findings, based on the guidelines developed by the Organization^{viii)}
- (4) Audit of all Contracting Governments shall be:
 - 4.1 based on an overall schedule developed by the Secretary-General of the Organization, taking into account the guidelines developed by the Organization^{ix)}; and
 - 4.2 conducted at periodic intervals, taking into account the guidelines developed by the Organization^{x)}

i) The provision is included for practical reasons to ensure completeness in the reproduction of the international regulations. For the EU, the relationship is regulated by the DIRECTIVE 2009/15/EC OF THE EUROPEAN PARLIAMENT AND OF THE COUNCIL on common rules and standards for ship inspection and survey organisations and for the relevant activities of maritime administration as amended by the Commission Implementing Directive 2014/111/EU and Regulation (EC) No 391/2009 of the European Parliament and of the Council on common rules and standards for ship inspection and survey organisations as amended by Commission Implementing Regulation (EU) No 1355/2014

ii) Refer to the Framework and Procedures for the IMO Member State Audit Scheme, adopted by the Organization by resolution A.1067(28)

iii) Refer to the Code on Intact Stability, 2008 for All Types of Ships covered by IMO Instruments, adopted by the Organization by resolution MSC. 267(85) as amended.

iv) Deadlights are fitted to the inside of windows and side scuttles, while storm covers are fitted to the outside of windows, where accessible, and may be hinged or portable.

v) Oil tankers, chemical tankers and gas carriers are defined in the International Convention for the Safety of Life at Sea (SOLAS), 1974, regulations II-1/2.12, VII/8.2 and VII/11.2. respectively.

vi) Reference is made to the Code of Safe Practice for Ships Carrying Timber Deck Cargoes, adopted by the Organization by resolution A.715(17) , as amended

vii) Refer to the Framework and Procedures for the IMO Member State Audit Scheme, adopted by the Organization by resolution A.1067(28)

viii) Refer to the Framework and Procedures for the IMO Member State Audit Scheme, adopted by the Organization by resolution A.1067(28).

ix) Refer to the Framework and Procedures for the IMO Member State Audit Scheme, adopted by the Organization by resolution A.1067(28).

x) Refer to the Framework and Procedures for the IMO Member State Audit Scheme, adopted by the Organization by resolution A.1067(28).
